



UL Guide for MiSA™-a12



For additional information, please visit OventionOvens.com

"The Ovention oven not only kept up but it also saved me \$80,000 because I didn't need to invest in a hood system and other fire-suppression equipment."

- Happy Ovention Customer

[Click to jump to section](#)

Table of Contents

Spec Sheet.....	3
UL Certificate.....	5
SAN Certificate.....	7
Ovention, Inc. KNLZ US.....	9
Ovention, Inc. KNLZ Canada.....	11
KNLZ Explained.....	15
Ovention, Inc. KQSQ US.....	19
Ovention, Inc. KQSQ Canada.....	20
Ovention, Inc. TSQT.....	21
EPA Letter.....	22
EPA Test Explanation.....	33
Energy Report.....	34
Operation Manual.....	35

Looking for something else? Let us know!

connect@oventionovens.com



The MiSA™ -a12



Air + Microwave = Improved Rapid Cook

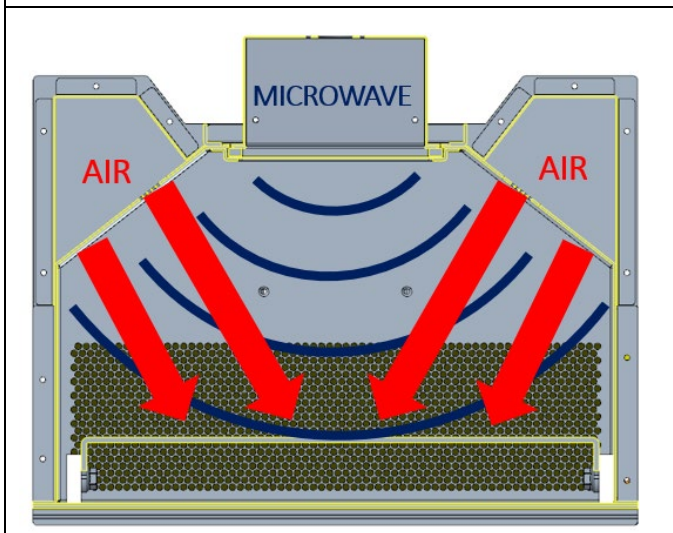

SHORT FORM SPECIFICATIONS: Provide Ovention MiSA™-a12 Microwave and Convection Oven, electric, certified ventless, 13.6x5.4" cavity, capacitive touch screen display with security passcode and countdown timer, USB menu load capability, one 1/3HP variable-speed motor, internal catalytic filtration, removable filters, stainless steel door, 304 stainless steel interior, 430 stainless steel top, sides & back, 4" optional legs, 2060 W microwave power, 5200 W Convection power, 208-240v/60/1-ph, 24 amps, NEMA 6-30-P, UL Listed, UL EPH Classified, Made in USA.

STANDARD FEATURES

- ✓ Temperature range: 200°F-525°F
- ✓ Highest convection heat, largest cavity volume, and quietest work environment in its market segment (68 dB)
- ✓ Full-color 7" touchscreen display with passcode
- ✓ Low energy consumption
- ✓ Microwave stirrers to evenly distribute microwave
- ✓ Patent pending cook plate technology gives even browning to the bottom of food products
- ✓ 176.1 square inch cavity offers more usable space

OPERATION

- ✓ USB port - upload and download recipes, view cook logs, diagnostic mode
- ✓ 1,000+ recipes
- ✓ Recipes up to three stages with variable time, temperature, blower speeds, and microwave power during each stage

PERFORMANCE

- ✓ Smallest footprint rapid cook that accommodates a ¼ size sheet pan (9"x13") and 12" pizza
- ✓ Adaptive voltage sense that adjusts to the incoming power supply
- ✓ Up to 10 times faster than conventional ovens
- ✓ Use any oven-safe pans. Accessory pans available for scoring products or cooking specialty items

CONSTRUCTION

- ✓ 304 stainless interior, 430 stainless exterior
- ✓ Easy to clean design: Filters are dishwasher safe, trays are removable for easy cleaning
- ✓ PTFE lined (nonstick) cavity

VENTILATION

- ✓ No hood system required*
- ✓ Performs 3x better than the required UL grease emission standard

*Type 2 hood necessary if HVAC cannot accommodate thermal load

PROUDLY MADE IN THE USA



Ask about our **anti-microbial powder coat** - standard for all available colors



OventionOvens.com | 855.298.6836 | connect@ventionovens.com

Search Ovention to download our app.



The MiSA™ -a12 Oven

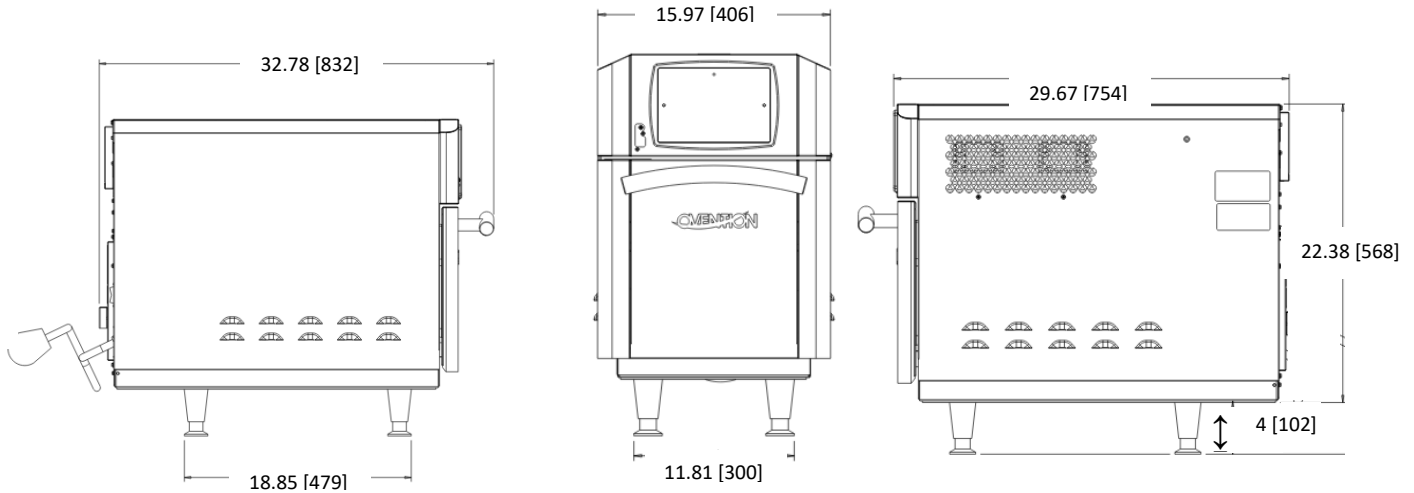

Measurement Units: Inches [Millimeters]

DIMENSIONS		
Height	22.38"	568 mm
With Legs (Optional)	26.38"	670 mm
Width	15.97"	406 mm
Depth	29.67"	754 mm
Cord Length	72"	1829 mm
CAVITY DIMENSIONS		
Height	5.41"	137 mm
Width	12.90"	327 mm
Depth	13.56"	344 mm
Weight	205 LB	93 Kg
Minimum Clearance	0" Left	0 mm Left
	0" Back	0 mm Back
	0" Right	0 mm Right

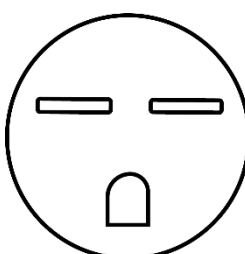
ELECTRICAL SPECIFICATIONS			
Model Number	MiSA-a12		
Temperature	200-525 °F	149-274° C	
Voltage	208-240V	 <p>NEMA 6-30</p>	
Amperage	19-24 A		
Phase	1		
Frequency	60 Hz		
Microwave Power*	2060W		
Convection Power*	5200W		
Nominal Microwave Frequency	2450 MHz		
Combination Power Output	3952-5760W		
SHIPPING			
Cube (LxWxH)	39x31x35"		990x787x889 mm
Shipping Weight	214 lb	97 kg	
Freight Class	110		
Point of Origin	Sturgeon Bay, Wisconsin, USA		

*This is NOT power consumption **Ovention, Inc. reserves the right to make technical improvements



OventionOvens.com | 855.298.6836 | connect@oventionovens.com

Search Ovention to download our app.



CERTIFICATE OF COMPLIANCE

Certificate Number UL-US-2021428-0
Report Reference E520667-20210331
Date 21-Apr-2021

Issued to: OVENTION INC
635 S 28Th St Milwaukee, WI
United States 53215

This is to certify that representative samples of KQSQ - Microwave Cooking Appliances
See Addendum Page for Product Designation(s).

Have been investigated by UL in accordance with the Standard(s) indicated on this Certificate.

Standard(s) for Safety: UL 923, 7th Ed., Revision Date: 2019-02-13

Additional Information: See the UL Online Certifications Directory at <https://iq.ulprospector.com> for additional information

This Certificate of Compliance does not provide authorization to apply the UL Mark. Only the UL Follow-Up Services Procedure provides authorization to apply the UL Mark.

Only those products bearing the UL Mark should be considered as being UL Certified and covered under UL's Follow-Up Services.

Look for the UL Certification Mark on the product.

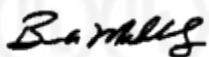

Bruce Mahrenholz, Director North American Certification Program

UL LLC

Any information and documentation involving UL Mark services are provided on behalf of UL LLC (UL) or any authorized licensee of UL. For questions, please contact a local UL Customer Service Representative at <http://ul.com/aboutul/locations/>



CERTIFICATE OF COMPLIANCE

Certificate Number UL-US-2021428-0
Report Reference E520667-20210331
Date 21-Apr-2021

This is to certify that representative samples of the product as specified on this certificate were tested according to the current UL requirements

Model	Category Description
MiSA-a12	Commercial Microwave/Convection Oven

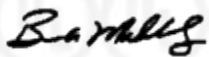

Bruce Mahrenholz, Director North American Certification Program

UL LLC

Any information and documentation involving UL Mark services are provided on behalf of UL LLC (UL) or any authorized licensee of UL. For questions, please contact a local UL Customer Service Representative at <http://ul.com/aboutul/locations/>



CERTIFICATE OF COMPLIANCE

Certificate Number UL-CA-2017491-0
Report Reference E520667-20210331
Date 21-Apr-2021

Issued to: OVENTION INC
635 S 28Th St Milwaukee, WI
United States 53215

This is to certify that representative samples of KQSQ7 - Microwave Cooking Appliances Certified for Canada
See Addendum Page for Product Designation(s).

Have been investigated by UL in accordance with the Standard(s) indicated on this Certificate.

Standard(s) for Safety: CSA C22.2 NO. 150-16, 4th Ed., Issue Date: 2016-08-01, Revision Date: 2017-02-01

Additional Information: See the UL Online Certifications Directory at <https://iq.ulprospector.com> for additional information

This Certificate of Compliance does not provide authorization to apply the UL Mark. Only the UL Follow-Up Services Procedure provides authorization to apply the UL Mark.

Only those products bearing the UL Mark should be considered as being UL Certified and covered under UL's Follow-Up Services.

Look for the UL Certification Mark on the product.

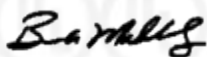

Bruce Mahrenholz, Director North American Certification Program

UL LLC

Any information and documentation involving UL Mark services are provided on behalf of UL LLC (UL) or any authorized licensee of UL. For questions, please contact a local UL Customer Service Representative at <http://ul.com/aboutul/locations/>



CERTIFICATE OF COMPLIANCE

Certificate Number UL-CA-2017491-0
Report Reference E520667-20210331
Date 21-Apr-2021

This is to certify that representative samples of the product as specified on this certificate were tested according to the current UL requirements

Model	Category Description
MiSA-a12	Commercial Microwave/Convection Oven

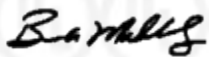

Bruce Mahrenholz, Director North American Certification Program

UL LLC

Any information and documentation involving UL Mark services are provided on behalf of UL LLC (UL) or any authorized licensee of UL. For questions, please contact a local UL Customer Service Representative at <http://ul.com/aboutul/locations/>



CERTIFICATE OF COMPLIANCE

Certificate Number UL-US-2021429-0
Report Reference E520667-20210331
Date 21-Apr-2021

Issued to: OVENTION INC
635 S 28Th St Milwaukee, WI
United States 53215

This is to certify that representative samples of KNLZ - Commercial Cooking Appliances with Integral Systems for Limiting the Emission of Grease-laden Air
See Addendum Page for Product Designation(s).

Have been investigated by UL in accordance with the Standard(s) indicated on this Certificate.

Standard(s) for Safety: UL 197, 10th Ed., UL 710B, 2nd Ed., Issue Date: 2011-09-02, Revision Date: 2019-02-01

Additional Information: See the UL Online Certifications Directory at <https://iq.ulprospector.com> for additional information

This Certificate of Compliance does not provide authorization to apply the UL Mark. Only the UL Follow-Up Services Procedure provides authorization to apply the UL Mark.

Only those products bearing the UL Mark should be considered as being UL Certified and covered under UL's Follow-Up Services.

Look for the UL Certification Mark on the product.

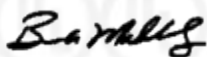

Bruce Mahrenholz, Director North American Certification Program

UL LLC

Any information and documentation involving UL Mark services are provided on behalf of UL LLC (UL) or any authorized licensee of UL. For questions, please contact a local UL Customer Service Representative at <http://ul.com/aboutul/locations/>



CERTIFICATE OF COMPLIANCE

Certificate Number UL-US-2021429-0
Report Reference E520667-20210331
Date 21-Apr-2021

This is to certify that representative samples of the product as specified on this certificate were tested according to the current UL requirements

Model	Category Description
MiSA-a12	Commercial Microwave/Convection Oven

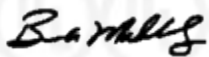

Bruce Mahrenholz, Director North American Certification Program

UL LLC

Any information and documentation involving UL Mark services are provided on behalf of UL LLC (UL) or any authorized licensee of UL. For questions, please contact a local UL Customer Service Representative at <http://ul.com/aboutul/locations/>



CERTIFICATE OF COMPLIANCE

Certificate Number UL-CA-2017492-0
Report Reference E520667-20210331
Date 21-Apr-2021

Issued to: OVENTION INC
635 S 28Th St Milwaukee, WI
United States 53215

This is to certify that representative samples of KNLZ7 - Commercial Cooking Appliances with Integral Systems for Limiting the Emission of Grease-laden Air Certified for Canada
See Addendum Page for Product Designation(s).

Have been investigated by UL in accordance with the Standard(s) indicated on this Certificate.

Standard(s) for Safety: CSA C22.2 NO. 109, 3rd Ed., Issued Date: 2017-05-01, Revision Date: 2021-03-01

Additional Information: See the UL Online Certifications Directory at <https://iq.ulprospector.com> for additional information

This Certificate of Compliance does not provide authorization to apply the UL Mark. Only the UL Follow-Up Services Procedure provides authorization to apply the UL Mark.

Only those products bearing the UL Mark should be considered as being UL Certified and covered under UL's Follow-Up Services.

Look for the UL Certification Mark on the product.

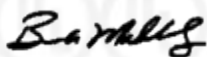

Bruce Mahrenholz, Director North American Certification Program

UL LLC

Any information and documentation involving UL Mark services are provided on behalf of UL LLC (UL) or any authorized licensee of UL. For questions, please contact a local UL Customer Service Representative at <http://ul.com/aboutul/locations/>



CERTIFICATE OF COMPLIANCE

Certificate Number UL-CA-2017492-0
Report Reference E520667-20210331
Date 21-Apr-2021

This is to certify that representative samples of the product as specified on this certificate were tested according to the current UL requirements

Model	Category Description
MiSA-a12	Commercial Microwave/Convection Oven

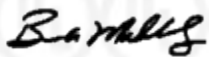

Bruce Mahrenholz, Director North American Certification Program

UL LLC

Any information and documentation involving UL Mark services are provided on behalf of UL LLC (UL) or any authorized licensee of UL. For questions, please contact a local UL Customer Service Representative at <http://ul.com/aboutul/locations/>



CERTIFICATE OF COMPLIANCE

Certificate Number R-E352231
Report Reference E352231-20210325
Date 2021-April-14

Issued to: OVENTION INC
635 S 28Th St
Milwaukee WI 53215 US

**This is to certify that
representative samples of**

COMMERCIAL COOKING, RETHERMALIZATION AND
POWERED HOT-FOOD-HOLDING AND -TRANSPORT
EQUIPMENT

See Addendum Page for Product Designation(s).

Have been investigated by UL in accordance with the
Standard(s) indicated on this Certificate.

Standard(s) for Safety: NSF 4, Commercial Cooking, Rethermalization, and
Powered Hot Food Holding and Transport Equipment

Additional Information: See the UL Online Certifications Directory at
<https://iq.ulprospector.com> for additional information

This Certificate of Compliance does not provide authorization to apply the UL Mark. Only the UL Follow-Up Services Procedure provides authorization to apply the UL Mark.

Only those products bearing the UL Mark should be considered as being UL Certified and covered under UL's Follow-Up Services.

Look for the UL Certification Mark on the product.



Bruce Mahrenholz, Director North American Certification Program

UL LLC

Any information and documentation involving UL Mark services are provided on behalf of UL LLC (UL) or any authorized licensee of UL. For questions, please contact a local UL Customer Service Representative at <http://ul.com/aboutul/locations/>



CERTIFICATE OF COMPLIANCE

Certificate Number R-E352231
Report Reference E352231-20210325
Date 2021-April-14

This is to certify that representative samples of the product as specified on this certificate were tested according to the current UL requirements

Commercial Cooking, Rethermalization, and Hot Food Holding and Transport Equipment

SPECIFIC PRODUCT DESCRIPTION (Type and Model): Commercial Microwave/Convection Oven with Integral System for Limiting the Emission of Grease-Laden Air, Model MiSA-a12



Bruce Mahrenholz, Director North American Certification Program

UL LLC

Any information and documentation involving UL Mark services are provided on behalf of UL LLC (UL) or any authorized licensee of UL. For questions, please contact a local UL Customer Service Representative at <http://ul.com/aboutul/locations/>



UL Product iQ™



KNLZ.E520667 - Commercial Cooking Appliances with Integral Systems for Limiting the Emission of Grease-laden Air

Note: We are enhancing our systems and you may notice duplicate entries/missing/outdated data. During this interim period, please contact our Customer Service at <https://www.ul.com/about/locations>.

Commercial Cooking Appliances with Integral Systems for Limiting the Emission of Grease-laden Air

OVENTION INC

635 S 28Th St
Milwaukee, WI 53215 United States

E520667

Commercial Microwave/Convection Oven, Model(s): MiSA-a12

The appearance of a company's name or product in this database does not in itself assure that products so identified have been manufactured under UL's Follow-Up Service. Only those products bearing the UL Mark should be considered to be Certified and covered under UL's Follow-Up Service. Always look for the Mark on the product.

UL permits the reproduction of the material contained in the Online Certification Directory subject to the following conditions: 1. The Guide Information, Assemblies, Constructions, Designs, Systems, and/or Certifications (files) must be presented in their entirety and in a non-misleading manner, without any manipulation of the data (or drawings). 2. The statement "Reprinted from the Online Certifications Directory with permission from UL" must appear adjacent to the extracted material. In addition, the reprinted material must include a copyright notice in the following format: "© 2021 UL LLC"

UL Product iQ™



KNLZ7.E520667 - Commercial Cooking Appliances with Integral Systems for Limiting the Emission of Grease-laden Air Certified for Canada

Note: We are enhancing our systems and you may notice duplicate entries/missing/outdated data. During this interim period, please contact our Customer Service at <https://www.ul.com/about/locations>.

Commercial Cooking Appliances with Integral Systems for Limiting the Emission of Grease-laden Air Certified for Canada

OVENTION INC

635 S 28Th St
Milwaukee, WI 53215 United States

E520667

Commercial Microwave/Convection Oven, Model(s): MiSA-a12

The appearance of a company's name or product in this database does not in itself assure that products so identified have been manufactured under UL's Follow-Up Service. Only those products bearing the UL Mark should be considered to be Certified and covered under UL's Follow-Up Service. Always look for the Mark on the product.

UL permits the reproduction of the material contained in the Online Certification Directory subject to the following conditions: 1. The Guide Information, Assemblies, Constructions, Designs, Systems, and/or Certifications (files) must be presented in their entirety and in a non-misleading manner, without any manipulation of the data (or drawings). 2. The statement "Reprinted from the Online Certifications Directory with permission from UL" must appear adjacent to the extracted material. In addition, the reprinted material must include a copyright notice in the following format: "© 2021 UL LLC"

KNLZ.GuidelInfo - COMMERCIAL COOKING APPLIANCES WITH INTEGRAL SYSTEMS FOR LIMITING THE EMISSION OF GREASE-LADEN AIR

[Heaters and Heating Equipment] (Heaters, Cooking Appliances) Commercial Cooking Appliances with Integral Systems for Limiting the Emission of Grease-laden Air

See General Information for Heaters, Cooking Appliances

USE AND INSTALLATION

This category covers cooking equipment intended for commercial use, such as pressurized deep fat fryers and other appliances for use in commercial kitchens, restaurants or other business establishments where food is prepared. Each appliance covered under this category is manufactured with an integral system feature to limit the emission of grease-laden air from the cooking process to the room ambient.

These appliances have been investigated for the limit of 5 mg/m³ for the emission of grease-laden air to the room ambient in accordance with the recommendations of ANSI/NFPA 96, "Ventilation Control and Fire Protection of Commercial Cooking Operations," using the EPA-202 test method prescribed for cooking appliances provided with integral recirculating air systems.

These products are not intended for connection to a ducted exhaust system.

Appliances in this category are not provided with an integral fire extinguishing system. Authorities having jurisdiction should be consulted as to the requirements for this equipment with respect to fire extinguishing systems, such as the need for field installed systems in accordance with ANSI/NFPA 96.

In cases where the nature or construction of equipment is such that special precautions beyond the requirements of ANSI/NFPA 70, "National Electrical Code," must be observed in installations or use, suitable warning or special instructions are marked on the equipment.

Appliances covered under this category are suitable for wiring with either copper or aluminum power-supply conductors unless marked "Use Copper Wire Only For Power Supply Connections."

Commercial cooking appliances of certain types are designed for permanent connections to water supply and sewer lines at the point of installation. Authorities having jurisdiction should be consulted as to the requirements for this equipment with respect to sanitation and connection to water supply and waste disposal lines.

FACTORS NOT INVESTIGATED

Neither the toxicity of coatings nor the physiological effects on persons consuming food products prepared by use of these appliances has been investigated.

PRODUCT IDENTITY

One of the following product identities appears on the product:

Commercial Cooking Appliance with Integral System for Limiting the Emission of Grease-laden Air

Cooking Appliance with Integral System for Limiting the Emission of Grease-laden Air

Other product identities may be used as shown in the individual certifications, followed by the words "with Integral System for Limiting the Emission of Grease-laden Air."

RELATED PRODUCTS

For products with integral recirculating systems including fire extinguishing systems, see Commercial, with Integral Recirculating Systems (KNKG).

For cooking oil filters that are not an integral part of another appliance, see Commercial Filters for Cooking Oil (KNRF).

ADDITIONAL INFORMATION

For additional information, see Electrical Equipment for Use in Ordinary Locations (AALZ) and Heating, Cooling, Ventilating and Cooking Equipment (AAHC).

REQUIREMENTS

The basic standard used to investigate products in this category is ANSI/UL 197, "Commercial Electric Cooking Appliances."

Appliances covered under this category with an integral cooking oil filter have been additionally investigated to ANSI/UL 1889, "Commercial Filters for Cooking Oil."

UL MARK

The Certification Mark of UL on the product is the only method provided by UL to identify products manufactured under its Certification and Follow-Up Service. The Certification Mark for these products includes the UL symbol, the words "CERTIFIED" and "SAFETY," the geographic identifier(s), and a file number.

Alternate UL Mark

The Listing Mark of UL on the product is the only method provided by UL to identify products manufactured under its Listing and Follow-Up Service. The Listing Mark for these products includes the UL symbol (as illustrated in the Introduction of this Directory) together with the word "LISTED," a control number, and the product name "Commercial Cooking Appliance" or "Cooking Appliance," or other appropriate product name as shown in the individual Listings, together with the words "with integral system for limiting the emission of grease-laden air."

* * * * *

UL, in performing its functions in accordance with its objectives, does not assume or undertake to discharge any responsibility of the manufacturer or any other party. UL shall not incur any obligation or liability for any loss, expense or damages, including incidental or consequential damages, arising out of or in connection with the use, interpretation of, or reliance upon this Guide Information.

Last Updated on 2013-05-16

The appearance of a company's name or product in this database does not in itself assure that products so identified have been manufactured under UL's Follow-Up Service. Only those products bearing the UL Mark should be considered to be Certified and covered under UL's Follow-Up Service. Always look for the Mark on the product.

UL permits the reproduction of the material contained in the Online Certification Directory subject to the following conditions: 1. The Guide Information, Assemblies, Constructions, Designs, Systems, and/or Certifications (files) must be presented in their entirety and in a non-misleading manner, without any manipulation of the data (or drawings). 2. The statement "Reprinted from the Online Certifications Directory with permission from UL" must appear adjacent to the extracted material. In addition, the reprinted material must include a copyright notice in the following format: "© 2019 UL LLC"



KQSQ.E520667 - Microwave Cooking Appliances

Note: We are enhancing our systems and you may notice duplicate entries/missing/outdated data. During this interim period, please contact our Customer Service at <https://www.ul.com/about/locations>.

Microwave Cooking Appliances

OVENTION INC

635 S 28Th St
Milwaukee, WI 53215 United States

E520667

Commercial Microwave/Convection Oven, Model(s): MiSA-a12

The appearance of a company's name or product in this database does not in itself assure that products so identified have been manufactured under UL's Follow-Up Service. Only those products bearing the UL Mark should be considered to be Certified and covered under UL's Follow-Up Service. Always look for the Mark on the product.

UL permits the reproduction of the material contained in the Online Certification Directory subject to the following conditions: 1. The Guide Information, Assemblies, Constructions, Designs, Systems, and/or Certifications (files) must be presented in their entirety and in a non-misleading manner, without any manipulation of the data (or drawings). 2. The statement "Reprinted from the Online Certifications Directory with permission from UL" must appear adjacent to the extracted material. In addition, the reprinted material must include a copyright notice in the following format: "© 2021 UL LLC"

UL Product iQ™



KQSQ7.E520667 - Microwave Cooking Appliances Certified for Canada

Note: We are enhancing our systems and you may notice duplicate entries/missing/outdated data. During this interim period, please contact our Customer Service at <https://www.ul.com/about/locations>.

Microwave Cooking Appliances Certified for Canada**OVENTION INC**

635 S 28Th St
Milwaukee, WI 53215 United States

E520667

Commercial Microwave/Convection Oven, Model(s): MiSA-a12

The appearance of a company's name or product in this database does not in itself assure that products so identified have been manufactured under UL's Follow-Up Service. Only those products bearing the UL Mark should be considered to be Certified and covered under UL's Follow-Up Service. Always look for the Mark on the product.

UL permits the reproduction of the material contained in the Online Certification Directory subject to the following conditions: 1. The Guide Information, Assemblies, Constructions, Designs, Systems, and/or Certifications (files) must be presented in their entirety and in a non-misleading manner, without any manipulation of the data (or drawings). 2. The statement "Reprinted from the Online Certifications Directory with permission from UL" must appear adjacent to the extracted material. In addition, the reprinted material must include a copyright notice in the following format: "© 2021 UL LLC"



TSQT.E352231 - Commercial Cooking, Rethermalization and Powered Hot-food-holding and -Transport Equipment

Commercial Cooking, Rethermalization and Powered Hot-food-holding and -Transport Equipment

OVENTION INC

635 S 28Th St
Milwaukee, WI 53215 United States

E352231

Commercial Microwave/Convection Oven with Integral System for Limiting the Emission of Grease-Laden Air Model(s) MiSA-a12

Convection Ovens, "Shuttle" Conveyor Type Model(s) S1200NC(*a), S1200NC3PH (*a), S1200NCCSA(*a), S2000NC(*a), S2000NC3PH (*a), S2000NCCSA(*a)

Convection Ovens, "Shuttle" Conveyor Type, with integral system for limiting the emission of grease-laden air Model(s) S1200(*a), S12003PH (*a), S1200CSA(*a), S1600 (*b), S2000(*a), S20003PH (*a), S2000CSA(*a)

Convection Ovens, Conveyor Type Model(s) C1200NC(*a), C1200NC3PH (*a), C1200NCCSA (*a), C1400NC(*a), C1400NC3PH(*a), C1400NCCSA(*a), C2000NC3PH (*a), C2000NCCSA (*a), C2600V(*b)

Convection Ovens, Conveyor Type, with integral system for limiting the emission of grease-laden air Model(s) C1200(*a), C12003PH (*a), C1200CSA(*a), C1400(*a), C14003PH(*a), C1400CSA(*a), C2000(*a), C2000CSA(*a), C2600 (*b)

Convection Ovens, Conveyor Type, with integral system for limiting the emission of grease-laden air, Model(s) C20003PH (*a)

Convection Ovens, Conveyor Types Model(s) C1200NCCSA(*a)\$, C2000NCCSA(*a)\$

Convection ovens, matchbox type, with integral system for limiting the emission of grease-laden air Model(s) M1313 (*a)\$, M1313CSA (*a)\$, M1718 (*a)\$, M1718CSA (*a)\$

Convection Ovens, with integral system for limiting the emission of grease-laden air Model(s) Elixir, M360, M360-14(*a), M360-16 (*a), MiLO-14, MiLO-16, MiLO2-16

*a - These C and S series ovens may be stacked up to 3 high using stacking kit, provided that both ovens are the same size \geq 1200 or 2000.

*b - These C and S series ovens may be stacked up to 2 high using stacking kit, provided that both ovens are the same size \geq 1600 or 2600.

Last Updated on 2021-04-14

The appearance of a company's name or product in this database does not in itself assure that products so identified have been manufactured under UL's Follow-Up Service. Only those products bearing the UL Mark should be considered to be Certified and covered under UL's Follow-Up Service. Always look for the Mark on the product.

UL permits the reproduction of the material contained in the Online Certification Directory subject to the following conditions: 1. The Guide Information, Assemblies, Constructions, Designs, Systems, and/or Certifications (files) must be presented in their entirety and in a non-misleading manner, without any manipulation of the data (or drawings). 2. The statement "Reprinted from the Online Certifications Directory with permission from UL" must appear adjacent to the extracted material. In addition, the reprinted material must include a copyright notice in the following format: "© 2021 UL LLC"



March 1, 2021

JEFF DIFFERT
HATCO CORP
STURGEON BAY PLANT 208 E DECK ST
STURGEON BAY, WI, 54235-3930

E-mail: JDIFERT@HATCOCORP.COM

Reference: Project: 4789642186

Product: EPA 202 TEST METHOD: CAPTURE AND EMISSION TESTS ON MICROWAVE
OVEN MODEL MiSA-a12

Dear Mr. Differt,

Any information and documentation involving UL Mark services are provided on behalf of UL LLC or any authorized licensee of UL.

Per your request, project 4789642186 was opened for the evaluation of grease-laden vapors produced from cooking pizzas in a microwave oven under a hood system.

The scope of this project was to determine the total grease emissions from cooking pepperoni pizzas as the specified food load in a commercial microwave oven while under the downdraft hood system as noted in Appendix A. Testing is conducted in accordance with EPA Method 202 test guidelines to determine ultimate results.

Results are used to determine compliance with Sections 58 and 59 of UL710B, the Standard for Recirculating Systems, formerly Section 14 of UL 197, Eighth Edition, Supplement SB, and paragraph 4.1.1.2 of NFPA96, the Standard for Ventilation Control and Fire Protection of Commercial Cooking Operations. The test was conducted at our facility in Northbrook, IL from May 19 to May 26, 2020. This letter will report the results of the EPA202 test.

For the record, the test was conducted using a hood with commercial microwave oven model MiSA-a12, Rated 208/240V, 24.0A, 60Hz. The test media as shown in Appendix A. A total of 241 pizzas were cooked for 1 minute, 45 seconds each. Test was a total of 8 hours. The results are considered to comply with UL710B,



Section 59, formerly Section 14 of UL 197, Eighth Edition, Supplement SB, and NFPA96, paragraph 4.1.1.2 when tested with your specified food load and requested cook times since the total amount of grease-laden effluents collected was 1.62 mg/m³, which is less than 5 mg/m³ limit. No evaluation was conducted in regards to fire protection. In addition, no evaluation of the cooking appliance itself or downdraft hood system was conducted in respects to safety and sanitation.

This letter will serve to report that all tests on the subject product have been completed. All information generated will be retained for future use. See Pages 3-11 for Test Results.

Thank you for the opportunity to provide your company with these services. Please do not hesitate to contact us if you should have any questions or comments.

Report By:

Stefan Torling
Staff Engineering Associate

Reviewed By:

Brandon Gray
Senior Staff Engineer

CLIENT INFORMATION	
Company Name	Hatco Corp
Address	Sturgeon Bay Plant 1118 S Neenah Sturgeon Bay WI 54235

AUDIT INFORMATION:				
Description of Tests	Per Standard No.	UL 197	Edition/Revision Date	10 th 2018-01-26
		CSA C22.2 No. 109-17		3 rd May, 2017
		UL 710B		2 nd 8/14/2014
<input checked="" type="checkbox"/> Tests Conducted by ¹ KRZYSZTOF SROKA				
<input checked="" type="checkbox"/> UL Staff supervising UL Staff in training Leo Carrillo				

TESTS TO BE CONDUCTED:				
Test No.	Done ³	Test Name	<input type="checkbox"/> Comments/Parameters <input type="checkbox"/> Tests Conducted by ² <input type="checkbox"/> Link to separate data files ⁴	
1	2021-02-24	POWER INPUT TEST (SINGLE PHASE RATED OVER 120V): RATING (CSA 22.2 109-M1981):		
2	2021-02-23	CAPTURE TEST:		
3	2021-02-26	EMISSION TEST:		

Instructions -

1 - When all tests are conducted by one person, name can be inserted here instead of including name on each page containing data.

2 - When test conducted by more than one person, name of person conducting the test can be inserted next to the test name instead of including name on each page containing data. Test dates may be recorded here instead of entering test dates on the individual datasheet pages.

3 - Use of this field is optional and may be employed differently. If used to include a date instead of entering the testing date on the individual datasheet pages, the date shall be the date the test was conducted.

4 - Link to separate data files for a test can be inserted here. The link must be to a server that is accessible to UL staff, that provides for backup, required retention periods and a path, including file name, that does not change and result in a broken link. Not applicable to DAP.

Special Instructions -

~~Unless specified otherwise in the individual Methods, the tests shall be conducted under the following ambient conditions. Confirmation of these conditions shall be recorded at the time the test is conducted.~~

Ambient Temperature, C ± Relative Humidity, % ± Barometric Pressure, mBar ±

No general environmental conditions are specified in the Standard(s) or have been identified that could affect the test results or measurements.

RISK ANALYSIS RELATED TO TESTING PERFORMANCE:

The following types of risks have been identified. Take necessary precautions. This list is not all inclusive.

<input checked="" type="checkbox"/> Electric shock	<input type="checkbox"/> Radiation
<input checked="" type="checkbox"/> Energy related hazards	<input type="checkbox"/> Chemical hazards
<input checked="" type="checkbox"/> Fire	<input type="checkbox"/> Noise
<input checked="" type="checkbox"/> Heat related hazards	<input type="checkbox"/> Vibration
<input checked="" type="checkbox"/> Mechanical	<input type="checkbox"/> Other (Specify)___

GENERAL TEST CONSIDERATIONS – ALL TESTS:

[Power Supply Connections]

Unless otherwise specified in the individual test methods, the appliance was connected to a 240 volt source of supply at 60 Hz.

This supply connection was based on

- The marked voltage rating
- The highest voltage of the applicable range of voltages

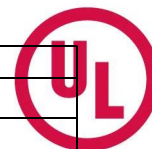

TEST LOCATION: (To be completed by Staff Conducting the Testing)					
<input checked="" type="checkbox"/> UL or Affiliate	<input type="checkbox"/> WTDP	<input type="checkbox"/> CTDP	<input type="checkbox"/> TPTDP	<input type="checkbox"/> TCP	<input type="checkbox"/> PPP
Company Name: UL LLC					
Address: 333 PFINGSTEN RD, NORTHBROOK IL 60062					

TEST EQUIPMENT INFORMATION

UL test equipment information is recorded on Meter Use.

TEST SAMPLE IDENTIFICATION:

The table below is provided to establish correlation of sample numbers to specific product related information. Refer to this table when a test identifies a test sample by "Sample No." only.

Sample Card No.	Date Received	Test No.+	Sample No.	Manufacturer, Product Identification and Ratings
3609176	2020-10-26	1	1	Ovention, Commercial Microwave Oven, Model MiSA-a12, Rated 208-240V, 60Hz, 24.0A

+ - If Test Number is used, the Test Number or Numbers the sample was used in must be identified on the data sheet pages or on the Data Sheet Package cover page.

~~Sampling Procedure~~

~~This document contains data or information using color and if printed, should be printed in color to retain legibility and the information represented by the color.~~

Inst. ID No.	Instrument Type	Test Number +, Test Title or Conditioning	Function/Range	Last Cal. Date	Next Cal. Date
137147	STACK SAMPLER	2	APEX UNIT	02-28-2020	02-28-2021
173628	STACK SAMPLER SOFTWARE	2	APEX UNIT SOFTWARE	02-28-2020	02-28-2021
76391	ROTRONIC HYGROLOG	2	HUMIDITY AND TEMP RECORDER	06-10-2020	06-30-2021
86991	COMBUSTION ANALYZER	2	O2- OK CO PPM – 76.0 / 396.0 CO2% - 1.94 / 14.66	--	--
3510206	DISTILLED WATER	2,3	DISTILLED WATER- S&R	--	--
1336223	425 PPM CARBON MONOXIDE	2	S&R	--	--
1415219	80 PPM CARBON MONOXIDE	2	S&R	--	--
1336225	NITROGEN	2	S&R	--	--

88483	FILTER/TRAY SCALE AND HR-300I	2,3	TRAY AND FILTER SCALE	01-22-2021	01-31-2022
63286	DESSICATOR	2,3	FILTER DESSICATOR	NCE	NCE
63290	DESSICATOR	2,3	TRAY DESSICATOR	NCE	NCE
24165	0-75 LB SCALE	2,3	WATER SCALE	04-22-2020	04-30-2021
2697901	SILICA GEL	2	SILICA GEL	S&R	
112012	FLUKE TEMP PROBE	2	TEMP PROBE FOR PIZZA	07-08-2020	07-31-2021
67227	FAN SPEED CONTROL	2	500 CFM	--	--
23714	DIGITAL PRESSURE GAUGE	2	28.9 IN. HGA	10-16-2020	10-31-2021
22709	DORIC-TRENDICATOR	2	TEMP-72F	06-05-2020	06-30-2021
156478	TIMER/STOP WATCH	2,3	STOP WATCH	02-13-2020	02-28-2025
139814	HOT WIRE/ALNOR/VELOMETER	2	HOT WIRE	11-12-2020	11-30-2021
176400	HOT WIRE/SOFTWARE	2	HOT WIRE S/OFTWARE	11-12-2020	11-30-2021
31120	ALNOR IN H2O	2	ALNOR, IN H2O	10-08-2020	10-31-2021
187571	CALIBRATED TAPE MEASURE	2	TAPE MEASURE	10-15-2020	10-31-2025
67239	VARIAC 240V 1PH	1,2	VARIAC	--	--
23630	POWER ANALYZER	1,2	POWER ANALYZER	08-12-2020	08-31-2021
3405801	METHYLENE CHLORIDE	3	S&R	--	--
3418686	ACETONE	3	S&R	--	--
58255	EPA 202 SPREADSHEET	2,3		--	--



POWER INPUT TEST (SINGLE PHASE RATED OVER 120V) :
 RATING (CSA 22.2 109-17) :

UL 197 Sec. 47 (6.2)



METHOD

[x] The supply voltage was adjusted to voltage and frequency as noted in "General Test Considerations", [240 V], [60 Hz].

The power input was measured with the appliance at the intended operating temperature under full-load conditions.

[X] (c-UL) To determine the proper test voltage for the Temperature (Normal) and Temperature (Abnormal) tests, the supply voltage was adjusted to the increased test voltage as noted below.

Increased Test Voltage (V_t): 216V for appliances rated 208V.
 250V for appliances rated between 220V-250V.

PARAMETERS

Appliance Ratings:

Volts: 208/240; Current: 24 A; Power: W

RESULTS

Operating Conditions	Specified			Measured			
	Volts, L1-L2	Amps		Power, (W)	Volts, L1-L2	Amps	Power, (W)
		L1	L2				
Full power operation, rated voltage	208	---	---	---	208	27.5	5602.4
[x] Full power operation, rated Current	---	24.0	---	---	187	24.0	4448.0
[x] Full power operation, 240 V	240	---	---	---	240.5	23.79	5547.0
c-UL Test Conditions							
Full power operation, increased test voltage	250	---	---	---	250	26.7	6555.0

[X] The input current ~~[was] [was not]~~ between 90% and 105% of the rated input current when the appliance was energized at rated voltage.

[x] The input power ~~[was] [was not]~~ between 90% and 105% of the rated input power when the appliance was energized at rated voltage.



METHOD

The model MiSA-a12 cooking appliance was placed under a hood operating at 500 CFM. Food product as specified below was then used for testing, see Emission Testing for specific details. The cooking area is to be observed for the presence of visible smoke and grease-laden air, and the hood assembly shall completely capture all of the emission as determined by observation.

COOKING PRODUCT

[x] Microwave Oven - 12 in. pepperoni pizza (Kirkland 12 in. pepperoni pizza), each cooked for 1 minute, 45 seconds with 0 seconds between loads for 8 hours (total of 241 pizzas). Oven was set to maintain 525°F

RECIPE

STAGE	TEMP F	BLOWER %	TIMER MM:SS	MICRO %
1	525	50%	01:00	100
2	525	100%	00:45	100

COOKING METHOD

[Microwave Oven]

Microwave Oven - 12 in. pepperoni pizza (Kirkland 12 in. pepperoni pizza, average 32 slices of pepperoni on each pizza), each cooked for 1 minute, 45 seconds with 0 seconds between loads for 8 hours (total of 241 pizzas). Oven was set to maintain 525°F

RESULTS

Their ~~[was]~~ [was not] the presence of visible smoke and grease-laden air from the appliance during testing.

The sample [did] ~~[did not]~~ capture all of the emissions from the cooking appliance.



METHOD

TEST FOR EVOLUTION OF SMOKE OR GREASE-LADEN AIR (525°F):

The model MiSA-a12 cooking appliance was placed under a hood operating at 500 CFM and was tested using a method derived from EPA Method 202. The Underwriters Laboratories provided Pepperoni Pizza for the test.

A 12 in. by 6 in. rectangular, 108 in. tall sheet metal stack was constructed on top of the hood. A sampling port was located approximately 80 in. downstream from the hood exhaust, at which point it was determined there was laminar flow. The sampler was assembled and an out of stack filter was used. A pre-leak check was conducted and determined to be < 0.02 ft/min. Sampling was determined to be done at 8 traverse points.

The oven was operated normally by cooking the following foods:

COOKING PRODUCT

- [x]** Microwave Oven - 12 in. pepperoni pizza (Kirkland 12 in. pepperoni pizza, average 32 slices of pepperoni on each pizza), each cooked for 1 minute, 45 seconds with 0 seconds between loads for 8 hours (total of 241 pizzas). Oven was set to maintain 525°F

RECIPE

STAGE	TEMP F	BLOWER %	TIMER MM:SS	MICRO %
1	525	50%	01:00	100
2	525	100%	00:45	100

The cooking cycle was repeated for 8 hours of continuous cooking.

During the cooking operation, it was noted whether or not visible effluents evolved from the air exhaust of the hood. Gauge, meter and temperature readings were taken and recorded every 10 min. After cooking, the condition of the duct was noted and a post-leak check was conducted and determined to be < 0.02 ft³/min.

After being allowed to cool, the sampling equipment was disassembled. The glass-filter is to be removed using a pair of forceps and placed in a clean petri dish. The dish is to be sealed and labeled "SAMPLE 1".

A sample of the acetone of the same volume that will be used to rinse-out the nozzle and probe is to be placed into a clean sample bottle, sealed, and labeled "SAMPLE 2". The level of the liquid in the sample bottle is to be recorded.



The inside of the nozzle and probe is to be rinsed with acetone taking care to collect all the rinse material in a clean sample bottle. The sample bottle is to be sealed, labeled "SAMPLE 3", and the level of the liquid in the bottle is to be recorded.

The liquid in the first three impingers is to be measured and the total volume is to be recorded which will be compared to the original volume. The liquid is to be quantitatively transferred to a clean sample bottle. Each impinger and the connecting glassware including the probe extension are to be rinsed twice with water. The rinse water is to be collected and added to the same sample bottle. The sample bottle is to be sealed, labeled "SAMPLE 4" and the level of the liquid in the bottle is to be recorded.

This rinse process is to be repeated with two rinses of methylene chloride (MeCl_2). The rinses are to be recovered in a clean sample bottle. The sample bottle is to be sealed, labeled "SAMPLE 5" and the level of the liquid in the bottle is to be recorded.

A volume of water approximately equivalent to the volume of water used to rinse and a volume of MeCl_2 approximately equivalent to the volume of MeCl_2 used to rinse is to be placed in two clean sample bottles. The sample bottles are to be sealed, labeled "SAMPLE 6" and "SAMPLE 7" respectively, and the level of the liquid in the bottles is to be recorded.

The weight of the fourth impinger containing the silica gel is to be recorded and then the silica gel can be discarded.

The analysis phase was done in accordance with EPA Method 202, using the out of stack filter.

RESULTS

The results [are] [~~are not~~] considered acceptable because there [was] [was no] visible smoke emitted from the exhaust of the hood during the normal cooking operation. There [was] [was no] noticeable amounts of smoke accumulated in the test room after 8 hours of continuous cooking.

The total amount of grease-laden effluents collected by the sampling equipment was found to be 1.62 mg/m^3 , which is [less] [~~more~~] than 5 mg/m^3 .

The total grease emissions (per clause 78.2 of 710B) in pounds per hour per linear foot of hood was $0.000825 \text{ lb/hr/ft}$.

Average Temperature during EPA 202: 86.4 F

Average Humidity during EPA 202: 23.7%

Note: Additional spreadsheet is to be used when conducting the Emission Test. This spreadsheet (EPA 202) can be found in the Lab Equipment Management System (LEM) under global ID 58255.



CONDENSIBLE MATTER
(Lab Analysis)

Sample Bottle No.	Description	Volume, ml	Final Wt, mg
2	Acetone (Blank)	90.0	0.6
3	Acetone (Wash)	90.0	0.9
4&5	Solvent Phase(Wash)	330.0	2.3
4&5	Water Phase (Wash)	290.0+500.0=790.0	6.5
6&7	Solvent Phase (Blank)	330.0	0.4
6&7	Water Phase (Blank)	500.0	3.5

Filter paper weight before test- 598.2 mg

Filter paper weight after test- 605.1 mg

Analysis

1. The liquid level of all the sample bottles is to be measured.
2. The filter from sample ONE is to be removed and dried to constant weight by means of a desiccator or an oven. The weight of the filter is to be recorded.
3. The volume of sample TWO is to be determined. The liquid is then to be transferred to a beaker and evaporated to dryness. The volume of the liquid and the final weight of the condensable matter are to be recorded.
4. The volume of sample THREE is to be determined. The liquid is then to be transferred to a beaker and evaporated to dryness. The volume of the liquid and the final weight of the condensable matter are to be recorded.
5. The volumes of sample FOUR and FIVE are to be measured.
6. Samples FOUR and FIVE are to be combined. The solvent phase is to be mixed, separated, and then repeated with two MeCl₂ washes.
7. The solvent extracts obtained from the procedure in 6 are to be placed in a beaker and evaporated to a constant weight. The final weight is to be recorded.
8. The water phase is to be placed in a beaker and evaporated to dryness. The final weight is to be recorded.
9. The volumes of samples SIX and SEVEN are to be determined. Sample bottles SIX and SEVEN are to be analyzed according to procedures 8 and 7 respectively.



11/14/2017

Mr. Scott Smith
Appliance Innovation Inc.
10500 Metric Dr, Suite 128
Dallas, TX 75243

Subject: Questions Concerning EPA202 Testing

Dear Scott,

This will follow up on conversation about the EPA202 Testing and applicable cooking procedures.

Clause 59.1.4 of UL710B states that the grease laden effluent at the exhaust outlet of the system shall not exceed an average of 5.0mg/m³ of exhausted air sampled at a maximum product capacity over a continuous 8 hour test cooking period.

The EPA202 Test was conducted on representative samples of your ovens. During this 8 hour test, the stack sampling nozzle was moved within the duct to obtain values over the face of the duct in 8 traverse points as dictated by clause 59.3.2. Each of these points was maintained for one hour during cooking.

Cooking for 8 hours at full oven capacity (as fast as possible) is done to represent and determine what the ovens grease production average output would be. Eight hours was done with each nozzle location representing one full hour to provide the best overall average per hour of effluent. It is not meant to indicate that the oven can only be used to cook for 8 hours in a commercial kitchen.

Should you have any questions or comments concerning the above, please feel free to contact the undersigned.

Sincerely,

A handwritten signature in black ink that reads "Fred Zaplatosch".

Fred Zaplatosch
Sr. Staff Engineer
Department: 3015GNBK
Tel: 847-664-2853
E-mail: fred.zaplatosch@ul.com

MiSA-a12

Ovention

Operating Time	12 Hours / day
Energy Cost	\$0.11 per kWhr
% of Day Cooking	10% Percent

Mode	Time (min)	Power (Watts)	Cost/Day
Warm up	8	5700	\$ 0.08
Cooking	71	4610	\$ 0.60
Idle	641	880	\$ 1.03

Total/Day	\$ 1.72
Total/Month	\$ 51.58
Total/Year	618.9058

Average Energy Cooking and Idle (J)	Warmup Energy (J)	Total Energy (J/Day)	Total average power (W)	Thermal load (kBTU/hr)	Average cooling requirement (ton of AC)
53,528,160	2,736,000	56,264,160	1,302	4.45	0.37

OVENTION[®]

THE ESSENCE OF COOKING[™]

MiSA[™]

Microwave Speed-Assist Oven

Model MiSA-a12

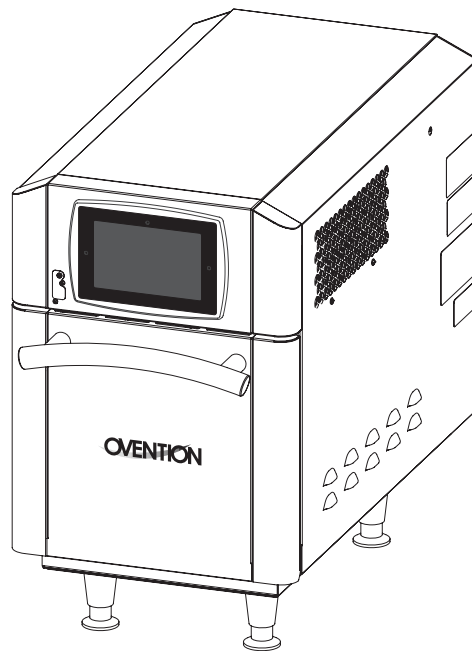

**See Operation
Manual**

Installation/Operating/Service Manual

⚠ WARNING

Do not operate this equipment unless you have read and understood the contents of this manual! Failure to follow the instructions contained in this manual may result in serious injury or death. This manual contains important safety information concerning the maintenance, use, and operation of this product. If you're unable to understand the contents of this manual, please bring it to the attention of your supervisor. Keep this manual in a safe location for future reference.

⚠ ADVERTENCIA

No opere este equipo al menos que haya leído y comprendido el contenido de este manual! Cualquier falla en el seguimiento de las instrucciones contenidas en este manual puede resultar en un serio lesión o muerte. Este manual contiene importante información sobre seguridad concerniente al mantenimiento, uso y operación de este producto. Si usted no puede entender el contenido de este manual por favor pregunte a su supervisor. Almacenar este manual en una localización segura para la referencia futura.

⚠ AVERTISSEMENT

Ne pas utiliser cet équipement sans avoir lu et compris le contenu de ce manuel ! Le non-respect des instructions contenues dans ce manuel peut entraîner de graves blessures ou la mort. Ce manuel contient des informations importantes concernant l'entretien, l'utilisation et le fonctionnement de ce produit. Si vous ne comprenez pas le contenu de ce manuel, veuillez le signaler à votre supérieur. Conservez ce manuel dans un endroit sûr pour pouvoir vous y référer plus tard.