

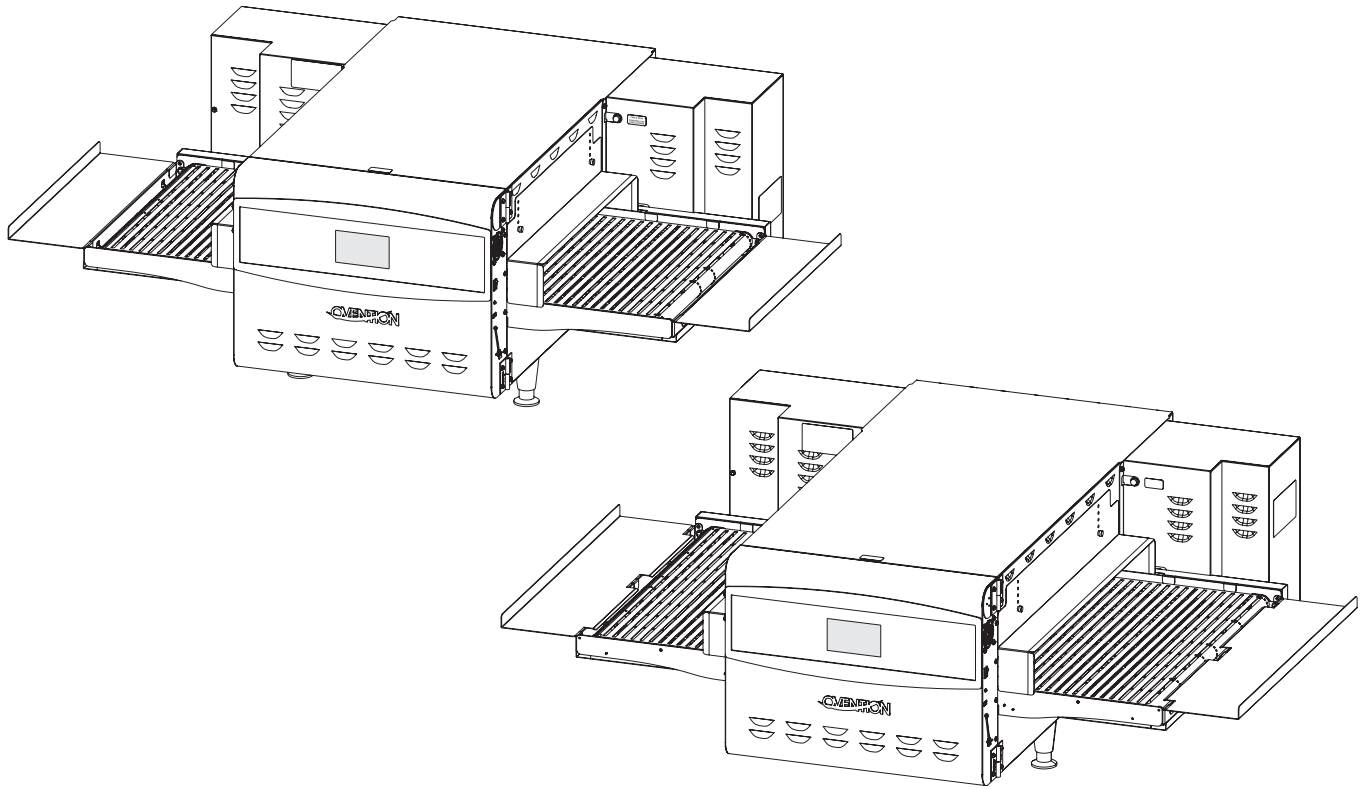

Conveyor Oven

Models: C1400, C2000, C2600



Installation and Operating Manual

⚠ WARNING

Do not operate this equipment unless you have read and understood the contents of this manual! Failure to follow the instructions contained in this manual may result in serious injury or death. This manual contains important safety information concerning the maintenance, use, and operation of this product. If you're unable to understand the contents of this manual, please bring it to the attention of your supervisor. Keep this manual in a safe location for future reference.

⚠ ADVERTENCIA

No opere este equipo al menos que haya leído y comprendido el contenido de este manual! Cualquier falla en el seguimiento de las instrucciones contenidas en este manual puede resultar en un serio lesión o muerte. Este manual contiene importante información sobre seguridad concerniente al mantenimiento, uso y operación de este producto. Si usted no puede entender el contenido de este manual por favor pregunte a su supervisor. Almacenar este manual en una localización segura para la referencia futura.

⚠ AVERTISSEMENT

Ne pas utiliser cet équipement sans avoir lu et compris le contenu de ce manuel ! Le non-respect des instructions contenues dans ce manuel peut entraîner de graves blessures ou la mort. Ce manuel contient des informations importantes concernant l'entretien, l'utilisation et le fonctionnement de ce produit. Si vous ne comprenez pas le contenu de ce manuel, veuillez le signaler à votre supérieur. Conservez ce manuel dans un endroit sûr pour pouvoir vous y référer plus tard.

CONTENTS

Important Owner Information	2	Operation	9
Introduction	2	General.....	9
Important Safety Information	3	Conveyor Setting Information.....	9
Model Designation	4	Startup.....	9
Model Description	4	Cooking—Single Belt.....	10
Specifications	6	Cooking—Split Belt.....	10
Plug Configurations.....	6	Shutdown.....	10
Electrical Rating Chart.....	6	Programming Conveyor Settings.....	11
Temperature Range.....	6	Changing Temperature Unit of Measure and	
Dimensions.....	7	Belt Direction.....	12
Installation	8	Uploading from a USB Drive.....	12
General.....	8	Maintenance	13
		General.....	13
		Daily Cleaning.....	13
		Monthly Cleaning.....	14
		Troubleshooting Guide	16
		Options and Accessories	17
		Limited Warranty	18

IMPORTANT OWNER INFORMATION

Record the model number, serial number, voltage, and purchase date of the unit in the spaces below (specification label located on the left side of the unit). Please have this information available when calling Ovention® for service assistance.

Model No. _____

Serial No. _____

Voltage _____

Date of Purchase _____

Business

Hours: 7:00 AM to 5:00 PM
Central Time (CT)

(Summer Hours: June to September –
7:00 AM to 5:00 PM Monday through Thursday
7:00 AM to 4:00 PM Friday)

Telephone: 855-298-6836 (Ovention Hotline)

E-mail: partsandservice@oventionovens.com

Additional information can be found by visiting our web site at www.oventionovens.com.



Need help?
Call our toll-free
Ovention Hotline
855-298-OVEN(6836)

INTRODUCTION

Ovention Conveyor Ovens set a new standard in cooking quality, speed, flexibility, and efficiency. A new discovery in air handling not only speeds the cooking process, but “scrubs” and recirculates the air through the oven—eliminating the need for a hood system in most installations (non-catalyst [NC] models require a hood system). Using an icon-driven touchscreen controller, operators can choose, edit, and develop custom conveyor settings easily. These settings can be developed to include varying heat profiles, upper and lower air velocity settings, and timing. Ovention Conveyor Ovens are designed specifically for ease of operation and high throughput.

Ovention Conveyor Ovens are products of extensive research and field testing. The materials used were selected for maximum durability, attractive appearance, and optimum performance. Every unit is inspected and tested thoroughly prior to shipment.

This manual provides the installation, safety, and operating instructions for Ovention Conveyor Ovens. Ovention recommends all installation, operating, and safety instructions appearing in this manual be read prior to installation or operation of the oven.

Safety information that appears in this manual is identified by the following signal word panels:



WARNING indicates a hazardous situation which, if not avoided, could result in death or serious injury.



CAUTION indicates a hazardous situation which, if not avoided, could result in minor or moderate injury.



NOTICE is used to address practices not related to personal injury.

IMPORTANT SAFETY INFORMATION



Read the following important safety information before using this equipment to avoid serious injury or death and to avoid damage to equipment or property.

⚠ WARNING

ELECTRIC SHOCK HAZARD:

- Plug unit into a properly grounded electrical receptacle of the correct voltage, size, and plug configuration. If plug and receptacle do not match, contact a qualified electrician to determine and install proper voltage and size electrical receptacle.
- Unit must be grounded properly. Failure to ground unit properly could result in serious personal injury or death.
- Turn off Standby switch, allow unit to cool, and turn off Main Disconnect switch/unplug unit before performing any cleaning, adjustments, or maintenance/service.
- DO NOT submerge or saturate with water. Unit is not waterproof. Do not operate if unit has been submerged or saturated with water.
- Unit is not weatherproof. Locate unit indoors where ambient air temperature is a minimum of 70°F (21°C) and a maximum of 100°F (38°C).
- Do not steam clean or use excessive water on unit.
- This unit is not “jet-proof” construction. Do not use jet-clean spray to clean this unit.
- Do not clean unit when it is energized or hot.
- Do not clean unit with metal scouring pads. Metal pieces can break off pad and touch electrical components, creating risk of electric shock.
- Do not pull unit by power cord.
- Keep power cord away from heated surfaces.
- Do not allow power cord to hang over edge of counter.
- Discontinue use if power cord is frayed or worn.
- Do not attempt to repair or replace a damaged power cord. Cord must be replaced by an Authorized Ovention Service Agent.
- This unit must be serviced by qualified personnel only. Service by unqualified personnel may lead to electric shock or burn.
- Use only Genuine Ovention Replacement Parts when service is required. Failure to use Genuine Ovention Replacement Parts will void all warranties and may subject operators of the equipment to hazardous electrical voltage, resulting in electrical shock or burn. Genuine Ovention Replacement Parts are specified to operate safely in the environments in which they are used. Some aftermarket or generic replacement parts do not have the characteristics that will allow them to operate safely in Ovention equipment.

EXPLOSION HAZARD: Do not store or use gasoline or other flammable vapors or liquids in the vicinity of this or any other appliance.

This oven is designed specifically to heat or cook—NOT for industrial or laboratory use.

⚠ WARNING

FIRE HAZARD:

- Do not install unit on or around combustible surfaces. Discoloration or combustion could occur. Unit must be installed in non-combustible surroundings only.
- Do not use an extension cord. If power cord is too short, contact a qualified electrician to determine and install proper voltage and size electrical receptacle near unit.

In the event of emergency, turn off Main Disconnect switch.

Unit may be located adjacent to a slippery floor.

Make sure all operators have been instructed on the safe and proper use of the unit.

This unit is not intended for use by children or persons with reduced physical, sensory, or mental capabilities. Ensure proper supervision of children and keep them away from the unit.

This unit has no “user-serviceable” parts. If service is required on this unit, contact an Authorized Ovention Service Agent or contact the Ovention Hotline at 855-298-6836.

⚠ CAUTION

BURN HAZARD:

- Some exterior surfaces on unit will get hot. Avoid unnecessary contact with unit.
- Pan/tray will be very hot upon removal—use oven mitt, pan gripper, or other utensil to remove.

Do not turn off Main Disconnect switch or unplug unit immediately after use. Internal fans must cool oven to avoid damage to electrical components.

Locate unit at proper counter height in an area that is convenient for use. Location should be level to prevent unit or its contents from falling accidentally and strong enough to support the weight of the unit and contents.

DO NOT lift unit by conveyor frame on each side of oven chamber. Conveyor is not designed to support weight of unit. Lift from underneath oven chamber only.

Do not move or relocate unit for cleaning. Unit is bulky and heavy.

Do not place anything on top of unit or stand on unit; doing so may subject personnel to injury or could damage unit.

Do not remove legs from bottom of unit in single stack installations.

Do not heat sealed containers or products such as whole eggs in oven. These items may explode.

Do not store any materials or items inside oven chamber when not in use.

SAVE THESE INSTRUCTIONS

IMPORTANT SAFETY INFORMATION

NOTICE

Do not spray cleaner directly onto touchscreens or into oven chamber. Improper cleaning of oven could damage screens/oven catalyst and will void unit warranty.

Do not install unit in locations with ambient air temperature that exceeds 100°F (38°C). Improper installation will damage unit and void unit warranty.

Allow the appropriate minimum clearance along the sides and rear of unit for proper ventilation. Do not block or cover any cabinet venting.

- Minimum clearance for single units and single-phase stacked units is 1" (25 mm).
- Minimum clearance for three-phase stacked units is 6" (152 mm).

NOTICE

Do not cover racks or any other part of oven with metal foil. Airflow restriction will cause oven to overheat.

Use non-abrasive cleaners and cloths only. Abrasive cleaners and cloths could scratch finish of unit, marring its appearance and making it susceptible to soil accumulation.

Do not lay unit on front or back side. Damage to unit could occur.

Clean unit daily to avoid malfunctions and maintain sanitary operation.

MODEL DESIGNATION

C x x x x xx

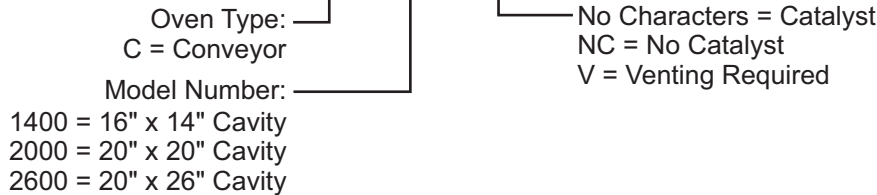

MODEL DESCRIPTION

All Models

Ovention® Conveyor Ovens are designed to provide unequalled flexibility in both kitchen and front-of-the-house installations. The superior cooking control, small footprint, low heat escape, and option for hood-less installation make the Conveyor Oven a modern solution for ease of operation and high throughput.

Each Conveyor Oven is equipped with dedicated upper and lower heating elements and air blowers. The air blowers direct heated air through upper and lower jet plates inside the oven chamber, above and below the food. A conveyor belt moves product continuously from one side of the conveyor, through the oven chamber, to the opposite side of the conveyor.

Operator controls consist of a touchscreen, a Standby switch, and a Main Disconnect switch (Models C2000 and C2600 only). Adjustable door tunnels on each side of the oven chamber can be used to customize the chamber opening height. Two removable crumb trays, one below each side of the conveyor, allow for easy cleanup. A USB port allows the uploading of pre-programmed menu items, installation of software updates, and opportunity for service diagnostics. A 6' (1829 mm) cord and plug set is standard.

Model C1400

Model C1400 is a standard, single belt conveyor oven. It has a 14" (356 mm) conveyor belt that can be set to cook from left-to-right or right-to-left.

Model C2000

Model C2000 has three different conveyor oven configurations—single belt, 50/50 split belt, and 70/30 split belt. The split belt models allow two different cook durations (belt speeds) to be running at the same time.

The single belt model has a 20" (508 mm) conveyor belt that can be set to cook from left-to-right or right-to-left.

The 50/50 split belt model has two separate 9-1/2" (241 mm) conveyor belts. Each can be operated independently and can be set to cook from left-to-right or right-to-left.

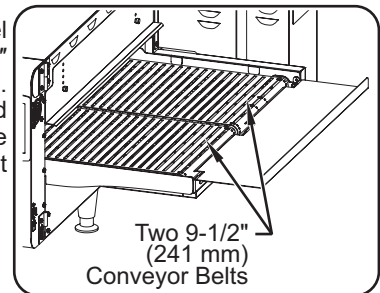

The 70/30 split belt model has a 12-1/2" (317 mm) conveyor belt and a 6-1/2" (165 mm) conveyor belt. Each can be operated independently and can be set to cook from left-to-right or right-to-left.

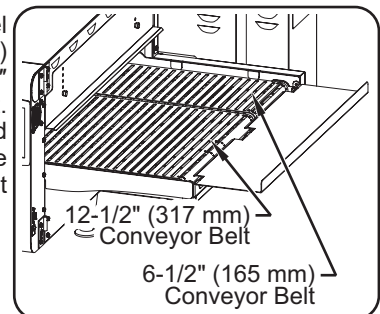

MODEL DESCRIPTION

Model C2600

Model C2600 has three different conveyor oven configurations—single belt, 50/50 split belt, and 70/30 split belt. The split belt models allow two different cook durations (belt speeds) to be running at the same time.

The single belt model has a 26" (659 mm) conveyor belt that can be set to cook from left-to-right or right-to-left.

The 50/50 split belt model has two separate 12" (304 mm) conveyor belts. Each can be operated independently and can be set to cook from left-to-right or right-to-left.

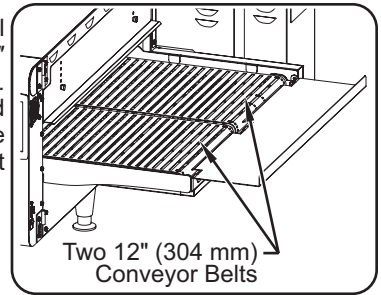

The 70/30 split belt model has a 17" (431 mm) conveyor belt and a 8" (203 mm) conveyor belt. Each can be operated independently and can be set to cook from left-to-right or right-to-left.

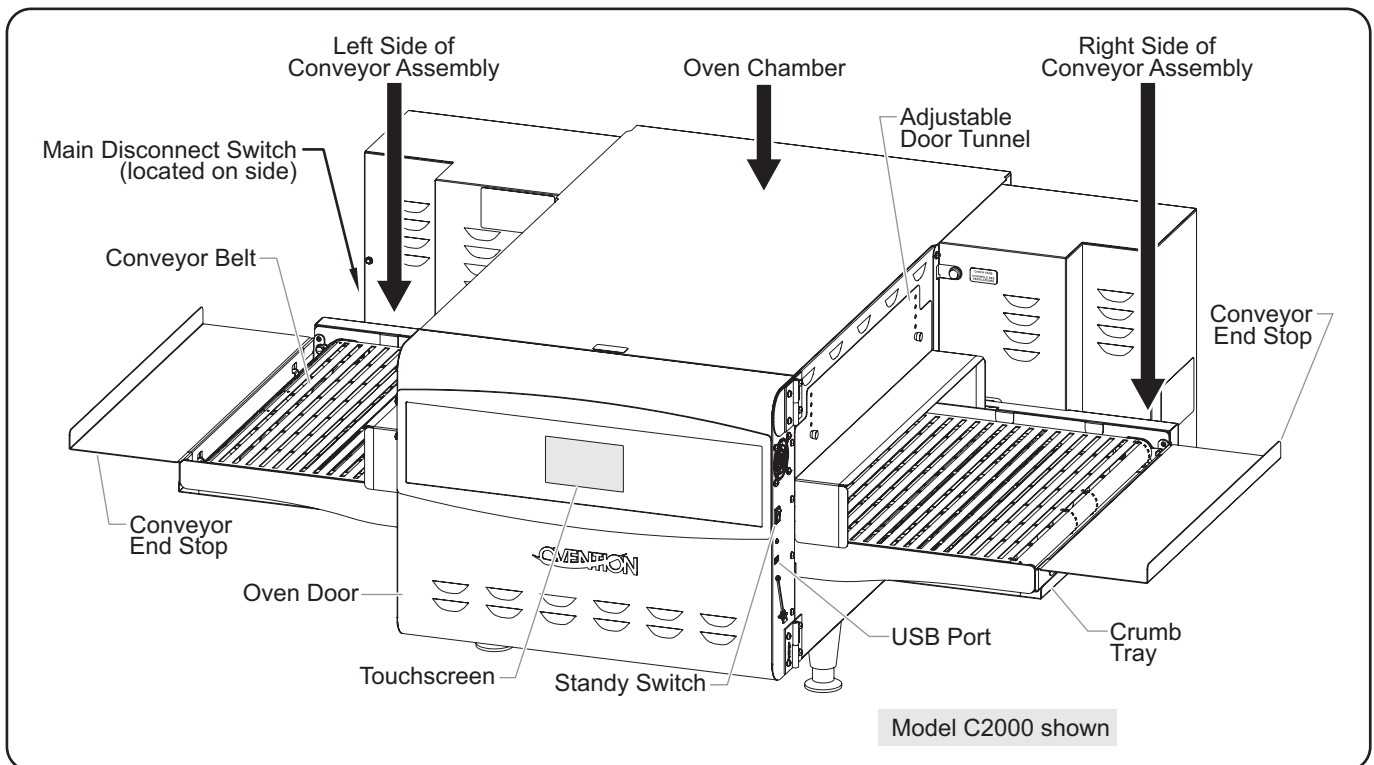
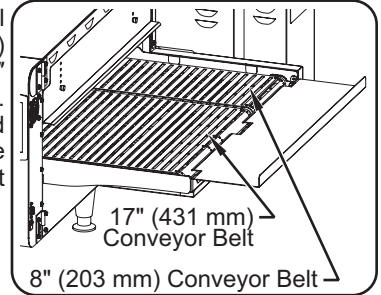

SPECIFICATIONS

Plug Configurations

Units are equipped with an electrical cord and plug appropriate for the electrical rating of the unit. Unit must be connected to a dedicated circuit.



ELECTRIC SHOCK HAZARD: Plug unit into a properly grounded electrical receptacle of the correct voltage, size, and plug configuration. If plug and receptacle do not match, contact a qualified electrician to determine and install proper voltage and size electrical receptacle.

NOTE: The specification label is located on the left side of the unit. See the label for the serial number and verification of unit electrical information.

NOTE: Receptacle not supplied by Ovention.

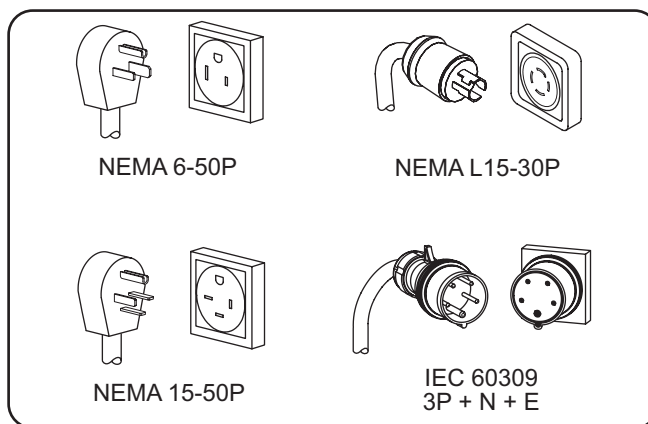

Plug Configurations

Electrical Rating Chart

Model	Voltage	Kilowatts	Amps	Phase	Hertz	Plug Configuration	Unit Weight
C1400	208/240	8.6/11.4	41/45	1	60	NEMA 6-50P	180 lbs. (82 kg)
C1400CSA			23.7/26	3		NEMA L15-30P	
C14003PH							
C1400	230/400	10.4	15.5	3	50	IEC 60309, 3P + N + E, 16 A	180 lbs. (82 kg)
C2000	208/240	9.3/12.3	44/49	1	60	NEMA 6-50P	226 lbs. (103 kg)
C2000CSA	208	8.5	40				
C20003PH	208/240	12.3/16.3	34	3		NEMA 15-50P	243 lbs. (110 kg)
C2000	230/400	15.0	22.1	3	50	IEC 60309, 3P + N + E, 32 A	243 lbs. (110 kg)
C2600	208/240	12.6/14.7	37	3	60	NEMA 15-50P	266 lbs. (121 kg)
C2600	230/400	17.2	25.3	3	50	IEC 60309, 3P + N + E, 32 A	266 lbs. (121 kg)

NOTE: Ovention Conveyor Ovens are designed to accept either 208 VAC or 240 VAC. The oven will adjust automatically to the input voltage.

The shaded areas contain electrical information for International models only.

Temperature Range

The operating temperature range of standard Conveyor Ovens is 300°–550°F (149°–288°C), except as shown below. All “No Catalyst” and “Venting Required” models have a temperature range of 300°–600°F (149°–316°C).

C2000 Single-Phase = 300°–525°F (149°–274°C)

C2000 Three-Phase = 300°–550°F (149°–288°C)

Dimensions

Model	Overall Width (A)	Depth (B)	Height (C)	Footprint Width (D)	Footprint Depth (E)	Rear Width (F)	Platform Width (G)	Body Width (H)	Platform Depth (J)
C1400	51-5/8" (1311 mm)	31-1/8" (790 mm)	20-1/4" (514 mm)	16-7/16" (417 mm)	22" (558 mm)	40-1/4" (1021 mm)	17-1/4" (438 mm)	17-1/8" (434 mm)	14-13/16" (376 mm)
C2000	60-1/4" (1531 mm)	37" (940 mm)	20-1/4" (514 mm)	20-5/16" (516 mm)	26" (659 mm)	44-1/8" (1120 mm)	19-11/16" (499 mm)	21" (533 mm)	20-13/16" (529 mm)
C2600	60-1/8" (1527 mm)	43" (1093 mm)	20-1/4" (514 mm)	20-5/16" (516 mm)	26" (659 mm)	44-1/8" (1121 mm)	19-5/8" (497 mm)	21" (533 mm)	26-13/16" (681 mm)

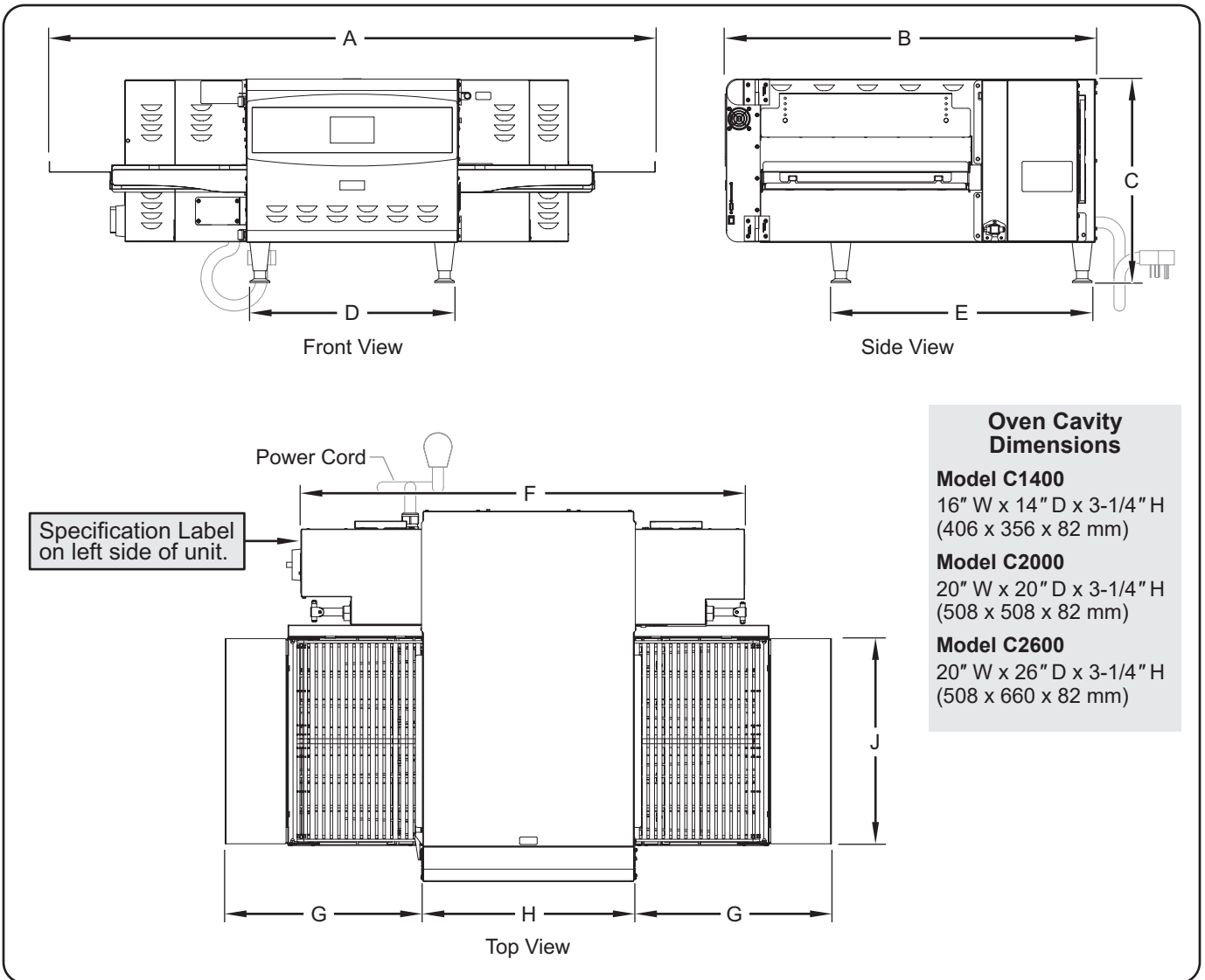

INSTALLATION

General

Ovention® Conveyor Ovens are shipped with most components pre-assembled. Care should be taken when unpacking shipping carton to avoid damage to the unit and components enclosed.

⚠ WARNING

ELECTRIC SHOCK HAZARD: Unit is not weatherproof. Locate unit indoors where ambient air temperature is a minimum of 70°F (21°C) and a maximum of 100°F (38°C).

FIRE HAZARD: Do not install unit on or around combustible surfaces. Discoloration or combustion could occur. Unit must be installed in non-combustible surroundings only.

⚠ CAUTION

Locate unit at proper counter height in an area that is convenient for use. Location should be level to prevent unit or its contents from falling accidentally and strong enough to support the weight of the unit and contents.

NOTICE

Do not install unit in locations with ambient air temperature that exceeds 100°F (38°C). Improper installation will damage unit and void unit warranty.

Do not lay unit on front or back side. Damage to unit could occur.

NOTE: Due to the size and weight of the Conveyor Oven, use the proper number of people for installation based on the weight of the oven.

1. Inspect the shipping container for obvious signs of transit damage. If damaged, inform the freight company immediately. **CAUTION! Stop! Do not attempt to use oven if damaged. Contact Ovention for assistance.**
2. Cut and remove the shipping bands from around the oven packaging.
3. Remove tape and protective packaging from all surfaces of the unit.
4. Remove crumb trays and conveyor end stops from packaging.
5. Inspect the oven for freight damage such as dents in the end caps or inside the oven chamber. If damaged, inform the freight company immediately.

⚠ CAUTION

DO NOT lift unit by conveyor frame on each side of oven chamber. Conveyor is not designed to support weight of unit. Lift from underneath oven chamber only.

6. Place the unit in the desired location. Make sure to lift from underneath the front and rear of the oven chamber.
 - Locate the unit in an area where the ambient air temperature is constant, a minimum of 70°F (21°C), and a maximum of 100°F (38°C).
 - Make sure the unit is at the proper counter height in an area convenient for use.
 - Make sure the countertop/table is level and strong enough to support the weight of the unit and food product.
 - Position the unit with the appropriate minimum clearance at the back and on either side for proper venting:

- 1" (25 mm) clearance for single units and single-phase stacked units.
- 6" (152 mm) clearance for three-phase stacked units.
- Make sure all the feet on the bottom of the unit are positioned securely on the countertop/table.

7. Install a crumb tray underneath each side of the conveyor.
 - Slide the tray underneath the conveyor and above the tray support located below the conveyor frame.
 - Position the two hooks on the tray into the holes at the end of the conveyor frame.

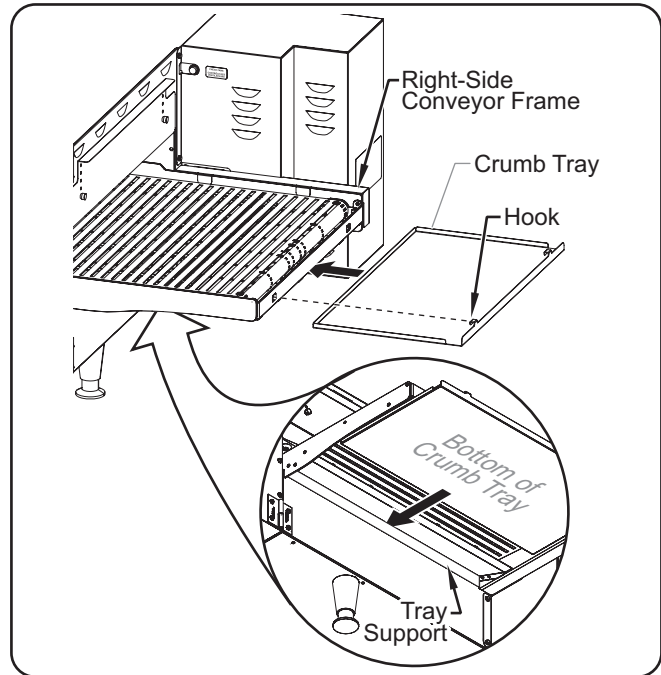

Installing a Crumb Tray

8. Install a conveyor end stop at each end of the conveyor frame.
 - Position the two hooks on the end stop over the conveyor frame while aligning the cutouts with the crumb tray hooks.

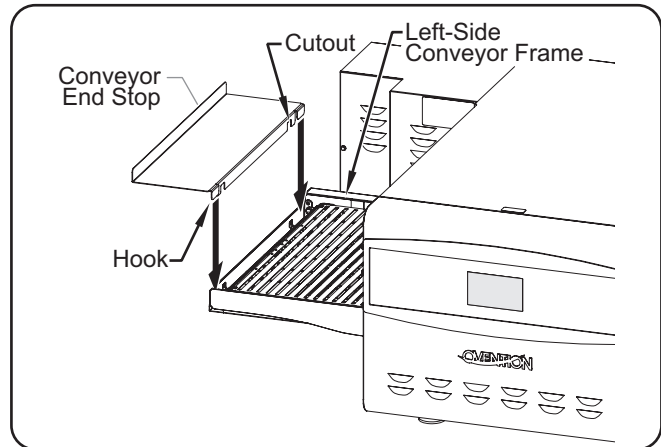

Installing a Conveyor End Stop

9. Plug the unit into a properly grounded electrical receptacle of the correct voltage, size, and plug configuration. See the SPECIFICATIONS section for details.

NOTE: The oven is suitable for either 208 VAC or 240 VAC and will adjust automatically to the voltage being supplied.

General

Use the following information and procedures to operate an Ovention® Conveyor Oven.



WARNING

Read all safety messages in the **IMPORTANT SAFETY INFORMATION** section before operating this equipment.

In the event of emergency, turn OFF Main Disconnect switch.



CAUTION

BURN HAZARD: Some exterior surfaces on unit will get hot. Avoid unnecessary contact with unit.

Use caution and be aware of pinch points when slider assembly is moving.

Conveyor Setting Information

Conveyor Ovens are designed to provide unequalled flexibility and efficiency. Each oven has the capability of storing 36 different conveyor settings. All conveyor settings appear on the Select Desired Item screen, which has eight additional sub-screens.

At initial startup, the Select Desired Item screen will show either sample conveyor settings or customer-specific, preloaded conveyor settings. If the Select Desired Item screen shows sample conveyor settings, these settings can be used to help develop specific conveyor settings appropriate for the installation. Refer to the “Programming Conveyor Settings” procedure in this section for instructions on creating conveyor settings.

Startup

1. Make sure the Main Disconnect switch is in the ON (I) position (Models C2000 and C2600 only).

NOTE: The Conveyor Oven can be set up to cook from left-to-right or right-to-left. This manual is written to reflect an oven set to cook from left-to-right. The conveyor belts on split belt models can travel in the same direction only.

2. Move the Standby switch up to the “On” position.
 - The touchscreen will energize and show the name of the oven and current software version for a few seconds.



Startup Screen

- After the Startup Screen, the Select Desired Item screen appears. The first four pre-set conveyor settings are available on this screen.

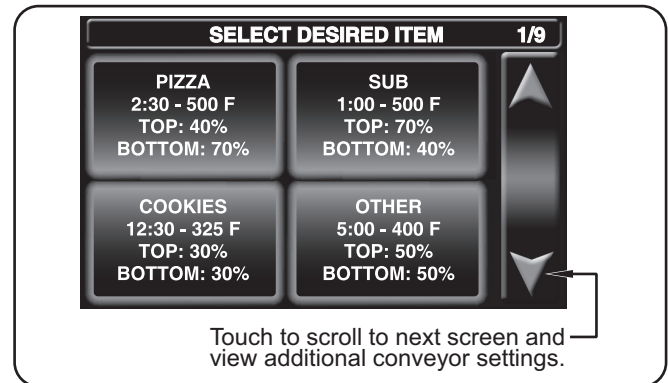

Select Desired Item Screen—Single Belt Model

3. Touch the desired conveyor setting.
 - The oven heaters, air blowers, and cooling fans will start up. Allow 10–15 minutes for the oven to reach setpoint temperature.
 - The touchscreen shows the selected setpoint temperature and the current cavity temperature.

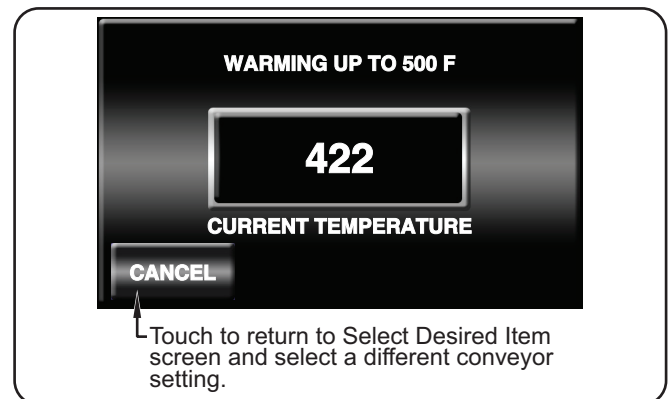

Preheat Screen

When the oven reaches setpoint temperature, the oven begins a temperature stabilizing period (a countdown screen appears).

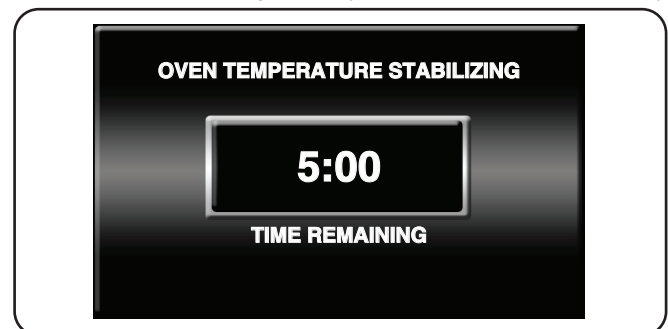

Oven Stabilizing Screen

After the oven temperature stabilizes, the conveyor belt begins moving and the Select Desired Item screen appears on the touchscreen. The oven is now ready for cooking.

NOTE: The conveyor settings shown are for example only. Depending on the configuration of the oven, the Select Desired Item screen will show either sample settings or customer-specific, preloaded settings.

OPERATION

Cooking—Single Belt

Use the following procedure to operate a single belt model and cook items continuously.

1. Make sure the oven has reached setpoint temperature. The Select Desired Item screen will appear on the touchscreen.

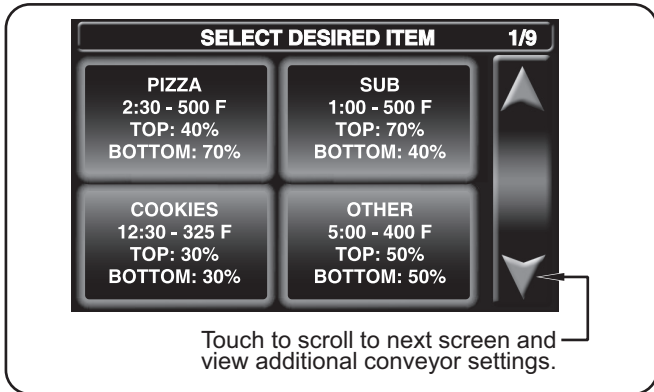

Select Desired Item Screen—Single Belt Model

2. Using a paddle, pan gripper, or other utensil, place food product onto the conveyor belt on the left side of the conveyor assembly.
 - Continue loading food product as needed.
3. Using a paddle, pan gripper, or other utensil, remove cooked food product from the right side of the conveyor assembly.

CAUTION

BURN HAZARD: Pan/tray will be very hot upon removal—use oven mitt, pan gripper, or other utensil to remove.

4. If a different conveyor setting is required during operation, touch the desired setting on the Select Desired Item screen.

NOTE: If the new conveyor setting temperature is different than the original temperature, the oven will need a few minutes to adjust to the new temperature.

Cooking—Split Belt

Use the following procedure to operate a split belt model and cook items continuously.

1. Make sure the oven has reached setpoint temperature. The Select Desired Item screen will appear on the touchscreen.

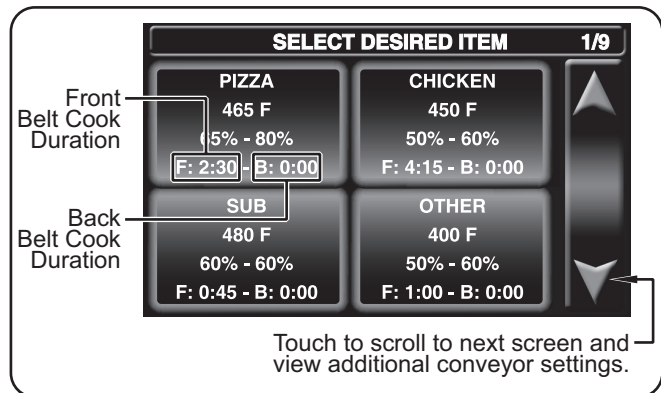

Select Desired Item Screen—Split Belt Model

NOTE: Split belt models are delivered from the factory with the Back Belt Cook Duration set to "0:00" for all conveyor settings. To adjust this setting, refer to "Programming Conveyor Settings" in this section.

2. Using a paddle, pan gripper, or other utensil, place food product onto the front or back conveyor belt on the left side of the conveyor assembly.
 - Continue loading food product onto the desired conveyor belt as needed.
3. Using a paddle, pan gripper, or other utensil, remove cooked food product from the right side of the conveyor assembly.

CAUTION

BURN HAZARD: Pan/tray will be very hot upon removal—use oven mitt, pan gripper, or other utensil to remove.

4. If a different conveyor setting is required during operation, touch the desired setting on the Select Desired Item screen.

NOTE: If the new conveyor setting temperature is different than the original temperature, the oven will need a few minutes to adjust to the new temperature.

Shutdown

1. Move the Standby switch down to the "Off" position.
 - The oven heaters, touchscreen, and conveyor belt will shut off.
 - The air blowers and cooling fans will continue to operate until the oven chamber temperature drops below 140°F (60°C).

CAUTION

Do not turn off Main Disconnect switch or unplug unit immediately after use. Internal fans must cool oven to avoid damage to electrical components.

Programming Conveyor Settings

Use the following procedure to edit or create conveyor settings. This procedure requires access to password-protected screens and should be performed by authorized personnel only.

NOTE: The USB port allows the uploading of pre-programmed conveyor settings from an external USB drive. Refer to the “Uploading from a USB Drive” procedure in this section for details.

- From the Select Desired Item screen, touch the “up” arrow.
 - A password keypad will appear on the touchscreen.
- Input the password using the keypad, and touch ENTER.
 - The Admin Mode screen will appear on the touchscreen.

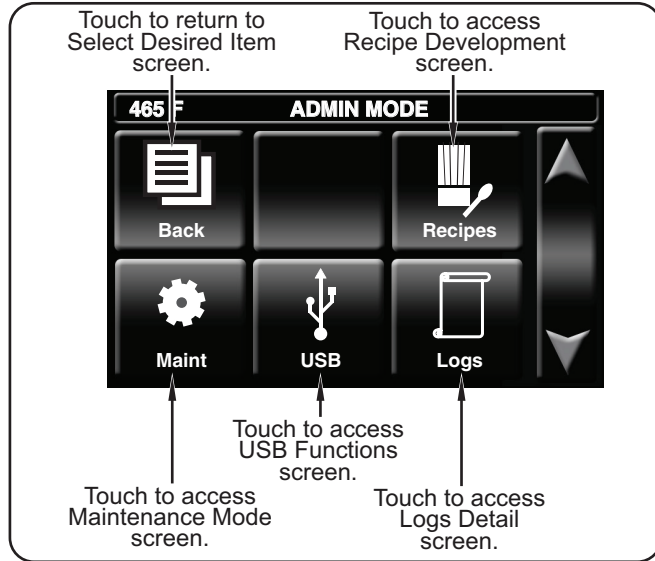

Admin Mode Screen

- Touch RECIPES to access the Recipe Development screen.
 - The Recipe Development screen will appear. This screen will look like the Select Desired Item screen.

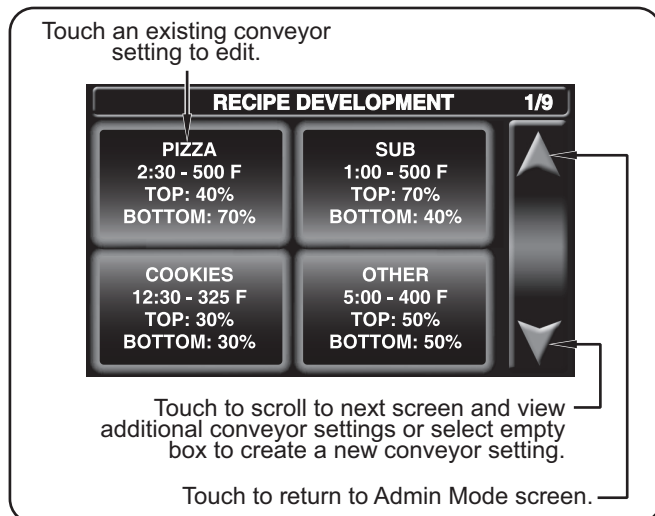

Recipe Development Screen—Single Belt Model

- Edit or create a conveyor setting.
 - To edit** an existing conveyor setting, touch the desired setting.
 - To create** a new conveyor setting, touch an empty box. If no empty boxes are available, touch the “down” arrow to scroll to the next screen.
 - The Edit Preset Data screen will appear.

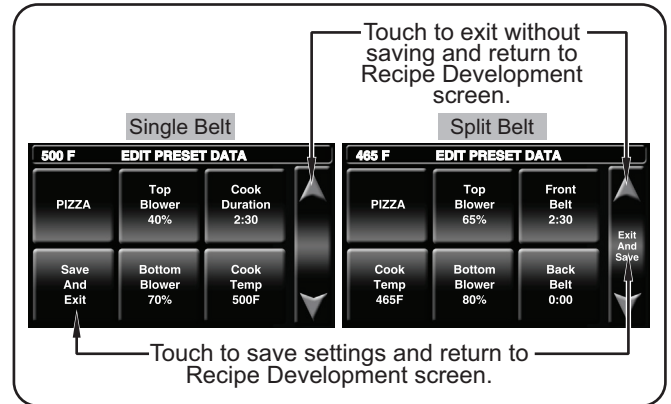

Edit Preset Data Screens

- Touch each “setting” box on the Edit Preset Data screen to edit the corresponding setting. Common settings include item name, top blower percentage, bottom blower percentage, and cook temperature. For cook duration: single belt models will have a single COOK DURATION box; split belt models will have a FRONT BELT box and a BACK BELT box.
 - Touching a “setting” box will bring up a keypad specific to the setting. Enter the desired value using the keypad, then touch ENTER to return to the Edit Recipe Settings screen.
 - Menu item names can have up to 16 characters.
- When conveyor setting programming is complete, touch SAVE AND EXIT on the Edit Preset Data screen.
 - The Recipe Development screen will appear.
 - To program additional menu items, repeat steps 4 and 5 of this procedure.
- If all programming is complete, touch the “up” arrow on the first (screen 1 of 9) Recipe Development screen to return to the Admin Mode screen.

OPERATION

Changing Temperature Unit of Measure and Belt Direction

Use the following procedure to change the temperature unit of measure between Fahrenheit and Celsius, as well as the direction that the conveyor belt moves. This procedure requires access to password-protected screens and should be performed by authorized personnel only.

- From the Select Desired Item screen, touch the “up” arrow.
 - A password keypad will appear on the touchscreen.
- Input the password using the keypad, and touch ENTER.
 - The Admin Mode screen will appear on the touchscreen.
- Touch MAINT to access the Maintenance Mode screen.

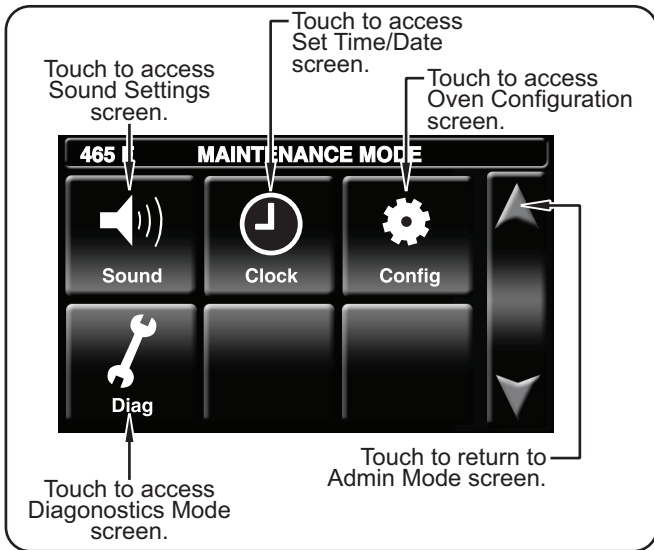

Maintenance Mode Screen

- Touch CONFIG on the Maintenance Mode screen. The Oven Configuration screen appears.
- Touch TEMP MODE on the Oven Configuration screen to toggle the unit of measure between Fahrenheit and Celsius.

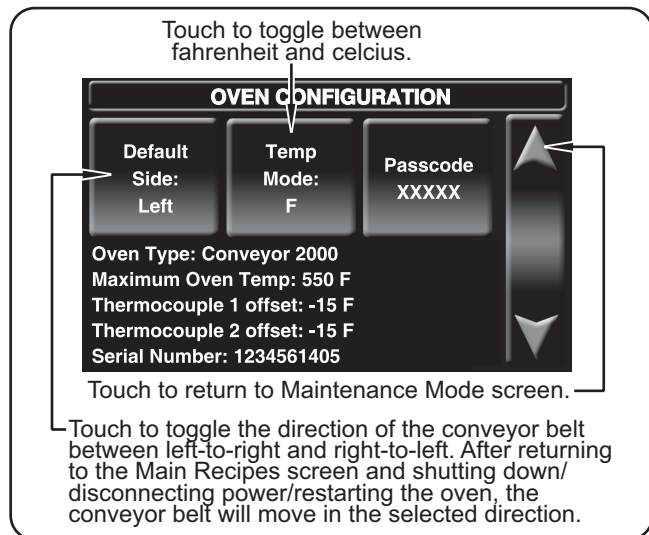

Oven Configuration Screen

Uploading from a USB Drive

Use the following procedure to upload pre-programmed menu items or firmware updates from an external USB drive. This procedure requires access to password-protected screens and should be performed at oven startup by authorized personnel only.

- Move the Standby switch up to the “On” position.
 - The touchscreen will energize. After the Startup Screen, the Select Desired Item screen appears.
- Remove the cover from the USB port above the Standby switch, and insert the USB drive into the port.
- From the Select Desired Item screen, touch the “up” arrow.
 - A password keypad will appear on the touchscreen.
- Input the password using the keypad, and touch ENTER.
 - The Admin Mode screen will appear on the touchscreen.
- Touch USB to access the USB Functions screen.

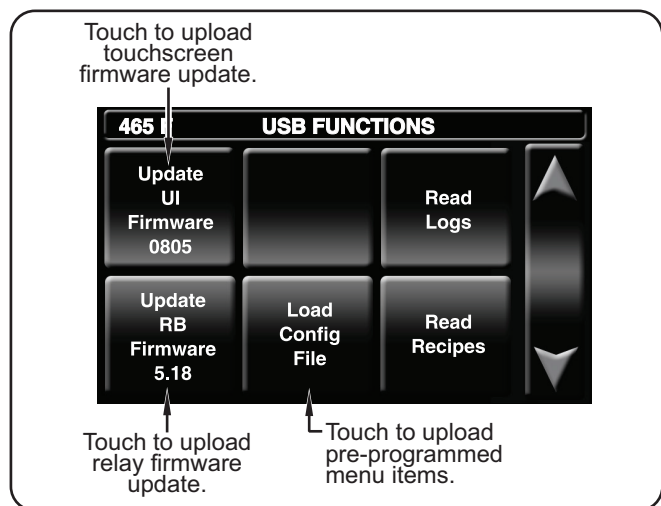

USB Functions Screen

- Touch the desired function to begin the corresponding upload.
 - Select the upload file from the list that appears.
 - A screen will appear to indicate that the upload is in progress.
 - When the upload is complete, the oven will restart.
- When the startup screens reappear, remove the USB drive from the USB port, and replace the port cover.
- Perform the normal “Startup” procedure at the beginning of this section to use the oven.

General

Ovention® Conveyor Ovens are designed for maximum durability and performance with minimum maintenance.

WARNING

ELECTRIC SHOCK HAZARD:

- Turn off Standby switch, allow unit to cool, and turn off Main Disconnect switch/unplug unit before performing any cleaning, adjustments, or maintenance/service.
- **DO NOT** submerge or saturate with water. Unit is not waterproof. Do not operate if unit has been submerged or saturated with water.
- Do not steam clean or use excessive water on unit.
- This unit is not “jet-proof” construction. Do not use jet-clean spray to clean this unit.
- Do not clean unit when it is energized or hot.
- Do not clean unit with metal scouring pads. Metal pieces can break off pad and touch electrical components, creating risk of electric shock.
- This unit must be serviced by qualified personnel only. Service by unqualified personnel may lead to electric shock or burn.
- Use only Genuine Ovention Replacement Parts when service is required. Failure to use Genuine Ovention Replacement Parts will void all warranties and may subject operators of the equipment to hazardous electrical voltage, resulting in electrical shock or burn. Genuine Ovention Replacement Parts are specified to operate safely in the environments in which they are used. Some aftermarket or generic replacement parts do not have the characteristics that will allow them to operate safely in Ovention equipment.

This unit has no “user-serviceable” parts. If service is required on this unit, contact an Authorized Ovention Service Agent or contact the Ovention Hotline at 855-298-6836.

CAUTION

Do not move or relocate unit for cleaning. Unit is bulky and heavy.

Never use steel pads, wire brushes, or scrapers to clean unit.

Wear protective rubber gloves and protective eyewear when cleaning unit.

NOTICE

Do not spray cleaner directly onto touchscreens or into oven chamber. Improper cleaning of oven could damage screens/oven catalyst and will void unit warranty.

Use non-abrasive cleaners and cloths only. Abrasive cleaners and cloths could scratch finish of unit, marring its appearance and making it susceptible to soil accumulation.

IMPORTANT NOTE:

Use of cleaning chemicals not approved by Ovention when cleaning the oven chamber will void the warranty.

Daily Cleaning

To maintain performance and preserve the finish of the Ovention Conveyor Oven, clean the unit daily.

CAUTION

Do not turn off Main Disconnect switch or unplug unit immediately after use. Internal fans must cool oven to avoid damage to electrical components.

1. Turn off the Standby switch and allow unit to cool. Cooling fans will operate until the oven chamber temperature drops below 140°F (60°C).
2. After the cooling fans shut off, disconnect the unit from the power supply:
 - For Model C1400, unplug the power cord.
 - For Models C2000 and C2600, move the Main Disconnect switch to the OFF (O) position, and unplug the power cord.
3. Remove and discard any remaining food product.
4. Remove any spillages using damp paper towel or a non-abrasive cloth.
5. Remove and clean each conveyor end stop using a damp paper towel.
6. Remove and clean each crumb tray.
 - Brush crumbs into a waste container.
 - Clean the tray using damp paper towel.
7. Reinstall the crumb trays and conveyor end stops (see OPERATION section for details).
8. Wipe down all exterior surfaces using a non-abrasive, damp cloth (a non-abrasive cleaner may be used for difficult stains).
9. Wipe dry all surfaces using a non-abrasive, dry cloth.
10. Polish the exterior surfaces of the oven using a good quality stainless steel cleaner.

MAINTENANCE

Monthly Cleaning

1. Turn off the Standby switch and allow unit to cool. Cooling fans will operate until the oven chamber temperature drops below 140°F (60°C).
2. After the cooling fans shut off, disconnect the unit from the power supply:
 - For Model C1400, unplug the power cord.
 - For Models C2000 and C2600, move the Main Disconnect switch to the OFF (O) position, and unplug the power cord.
3. Clean the Touchscreens.

NOTE: Do not spray cleaner directly onto the Touchscreens.

- a. Spray a mild degreaser onto a soft, damp non-abrasive cloth, and wipe the entire Touchscreen until clean. Repeat, if necessary.
 - b. Allow the Touchscreen to dry completely.
 - c. Wipe away any hazy residue that remains on the Touchscreen using a clean, dry non-abrasive cloth.
4. Remove and clean the two air filters on the back of the oven. To clean each filter:
 - a. Slide the filter straight out the side of the filter bracket.
 - b. Spray the filter with water and/or soak in mild soap and water.
 - c. Rinse clean and allow the filter to air dry.
 - d. When the filter is dry, reinstall the filter into the filter bracket.

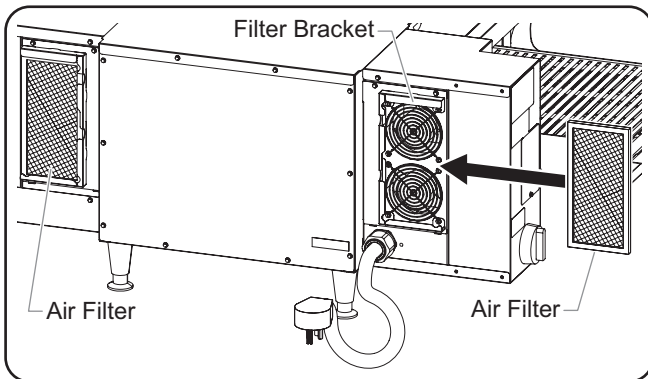

Cleaning the Air Filters

5. Using a soft bristle brush or compressed air, carefully clean dust/debris buildup on each front door cooling fan and fan guard.

IMPORTANT NOTE:

Use of cleaning chemicals not approved by Ovention when cleaning the oven chamber will void the warranty.

6. Remove and clean the upper and lower jet plates inside the oven chamber. To clean the jet plates:
 - a. Unlatch and open the oven door so that the inside of the oven chamber is exposed.
 - b. Remove each plate by gripping the two tabs on each plate and pulling straight out of the oven.
 - c. Spray Ovention Oven Cleaner onto both sides of each jet plate. Allow the cleaner to sit for 3–5 minutes.
 - d. Using a non-abrasive nylon scouring pad, apply pressure to wipe away grease residue.
 - e. Wipe the jet plates clean using a damp, non-abrasive cloth and allow to air dry. Do not reinstall at this time.

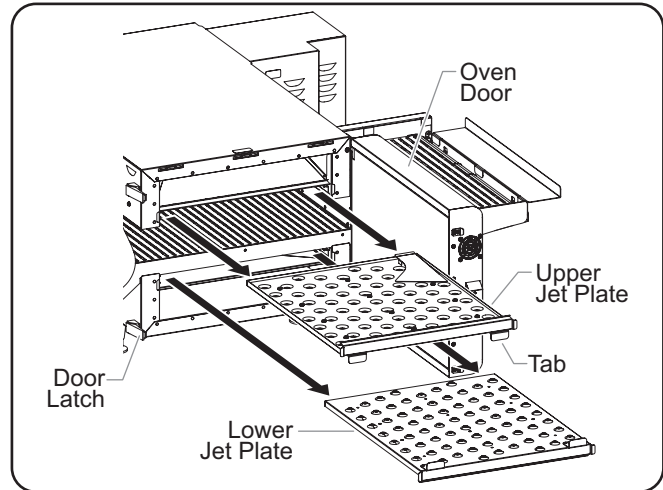

Cleaning the Jet Plates

7. Clean the visible areas of the oven chamber.
 - a. Spray Ovention Oven Cleaner onto a non-abrasive cloth, and wipe onto all the visible areas of the oven chamber. DO NOT spray cleaner directly into chamber. Allow the cleaner to sit for 3–5 minutes.
 - b. Using a non-abrasive nylon scouring pad, apply pressure to wipe away grease residue.
 - c. Wipe the oven chamber clean using a damp, non-abrasive cloth.
8. Reinstall the upper and lower jet plates into the oven chamber.
9. Close the oven door and secure both door latches.
10. Remove and clean each conveyor end stop and crumb tray as described in the "Daily Cleaning" procedure.

11. Remove the belt guard(s) and disengage the drive belt(s). Split belt models have a drive belt behind each side of the conveyor frame.
 - a. Slide the belt guard off the drive belt located behind the conveyor frame.
 - b. Remove the drive belt from the drive wheel by slightly lifting the conveyor frame.

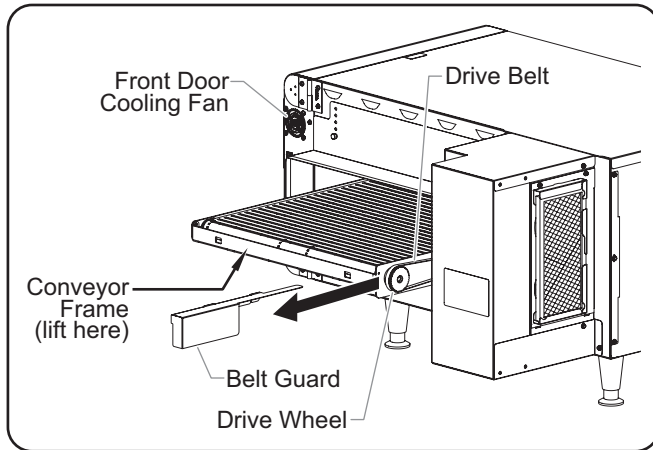

Removing the Belt Guard and Drive Belt

12. Clean the belt guard using mild soap and water. Rinse clean and dry using a non-abrasive cloth.
13. For split belt models only, remove the oven door to allow removal of the conveyor belt assembly.
 - a. Remove the two screws that secure the cover plate and upper door hinge to the oven door.
 - b. Disconnect the wire harness connectors located behind the cover plate, inside the door.
 - c. While supporting the oven door, unlatch and lift the door off the lower oven hinge.

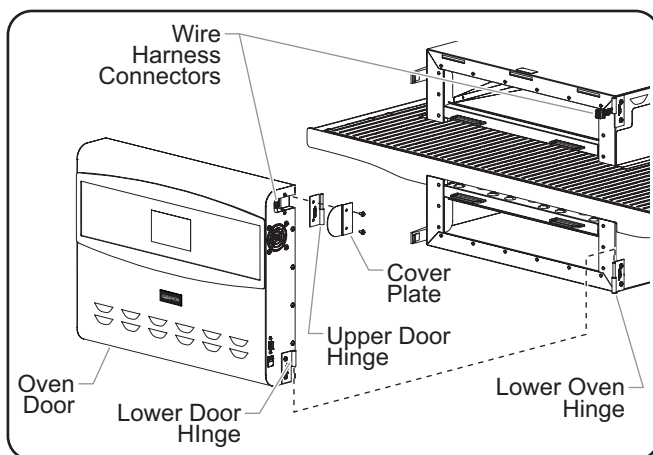

Removing the Oven Door—Split Belt Models Only

14. Remove the conveyor belt assembly. This step requires two people.

For single belt models:

- a. With one person on each side of the oven cavity, lift up the conveyor belt assembly and slide the entire assembly to the right.
- b. When most of the conveyor belt assembly is through the oven cavity, the person on the left should move to the right side of the oven cavity and continue sliding the assembly out of the cavity.

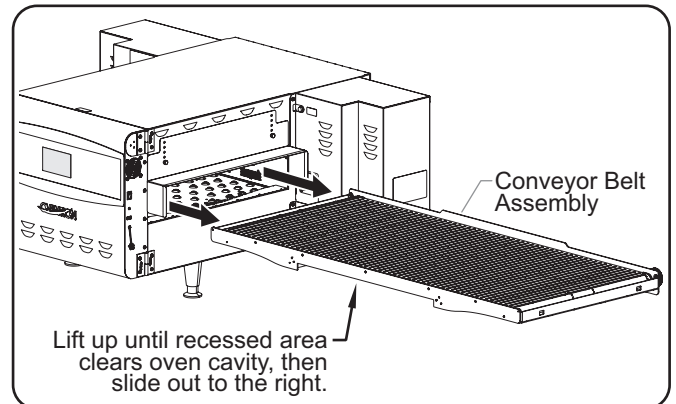

Removing the Conveyor Belt Assembly—Single Belt Model

For split belt models (oven door removed):

- a. With one person on each side of the oven cavity, lift up the conveyor belt assembly and slide the entire assembly out the front of the oven cavity.

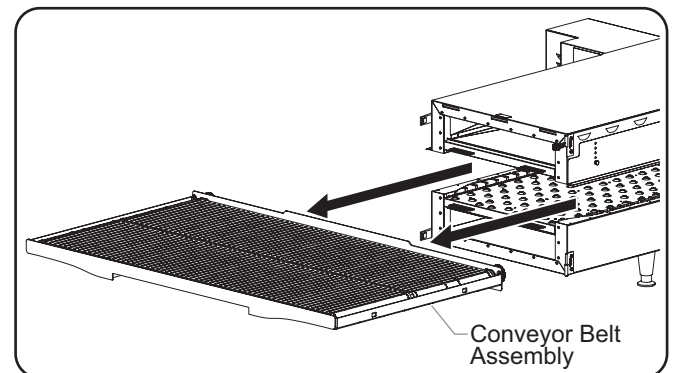

Removing the Conveyor Belt Assembly—Split Belt Model

15. Clean the conveyor belt assembly.
 - a. Spray Ovention Oven Cleaner onto both sides of the conveyor belt assembly. Allow the cleaner to sit for 3–5 minutes.
 - b. Using a non-abrasive nylon scouring pad, apply pressure to wipe away grease residue on the conveyor belt and frame.
 - c. Spray clean with water and dry using a non-abrasive cloth. Additional air dry time may be necessary before re-installation.
16. Reinstall the conveyor belt assembly, oven door, belt guard, crumb trays, and conveyor end stops by reversing the above procedure.

TROUBLESHOOTING GUIDE



WARNING

This unit must be serviced by qualified personnel only. Service by unqualified personnel may lead to electric shock or burn.



WARNING

ELECTRIC SHOCK HAZARD: Turn off Standby switch, allow unit to cool, and turn off Main Disconnect switch/unplug unit before performing any cleaning, adjustments, or maintenance/service.

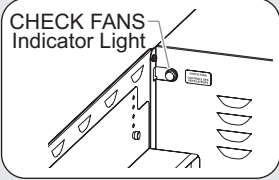
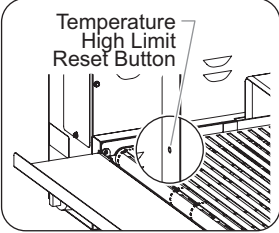
Symptom	Probable Cause	Corrective Action
Oven does not operate (blank touchscreen).	Standby switch turned off, Main Disconnect turned OFF (O), or unit unplugged.	Make sure unit is plugged in, Main Disconnect switch is in ON (I) position, and Standby switch is moved up to the "On" position.
	Unit connected to incorrect power supply.	Refer to SPECIFICATIONS section for unit electrical specifications. Contact a qualified electrician to determine and install proper voltage and size electrical receptacle.
Irregular belt movement.	Loose screw and/or bracket.	Check all screws on conveyor belt assembly. Tighten screws, if necessary.
	Malfunction of gear and/or drive belt.	Contact Authorized Service Agent or Ovention® Hotline for assistance.
	Incorrect software installed on oven operating system.	
Improper cooking of food.	Incorrect setpoint temperature/conveyor setting.	Verify desired setpoint temperature/conveyor setting. Change to proper settings, if necessary (refer to OPERATION section).
	Jet plate or air flow malfunction.	Contact Authorized Service Agent or Ovention Hotline for assistance.
CHECK FANS indicator light is on (located on front, right side of oven chamber). 	Ambient air temperature is over 95°F (35°C).	Light will illuminate in ambient temperatures over 120°F (49°C). Verify light shuts off after ambient temperature drops below 120°F (49°C) consistently. If not, see "Probable Causes" listed below.
	Air filters are dirty.	Check air filters and clean, if necessary. Refer to "Monthly Cleaning" procedure in MAINTENANCE section.
	Cooling fan(s) malfunction.	Contact Authorized Service Agent or Ovention Hotline for assistance.
Oven not heating. 	Temperature High Limit switch has tripped.	Press the Temperature High Limit Reset Button located on the left side of the oven chamber behind the conveyor frame. If switch continues to trip, contact Authorized Service Agent or Ovention Hotline for assistance.

To locate an Authorized Ovention® Service Agent:

- Access www.oventionovens.com, click on the *About Us* pull-down menu at the top of the page, and select "Find a Service Partner"
- Call the Ovention Hotline at 855-298-OVEN(6836)

Miscellaneous

OVNTN-FILReplacement Air Filter

OVNTN-CLNR.....Ovention Oven Cleaner, case of six bottles

NOTE: Use Ovention Oven Cleaner to clean cooking grease and residue safely from the jet plates, oven chamber, and conveyor belt assembly.

OVNTN-POLISHStainless Steel Cleaner and Polish

IMPORTANT NOTE

Additional accessories are available for Ovention Ovens. Contact the Ovention Hotline at 855-298-OVEN(6836) for information.

LIMITED WARRANTY

WARRANTY, EXCLUSIVE REMEDY:

Ovention, Inc. (Seller) warrants that the products it manufactures (Products) will be free from defects in materials and workmanship under normal use and service and when stored, maintained, and installed in strict accordance with factory recommendations. Seller's sole obligation to the person or entity buying the Products directly from Seller (Customer) under this warranty is the repair or replacement by Seller or a Seller-authorized service agency, at Seller's option, of any Product or any part thereof deemed defective upon Seller's examination, for a period of: (i) the Warranty Duration from the date of purchase by Seller or (ii) the Warranty Duration from the date of Product registration in accordance with Seller's written instructions, whichever is later. The "Warranty Duration" shall mean a period of one (1) year or the periods set forth below for specific Product components. Credit for Products or parts returned with the prior written permission of Seller will be subject to the terms shown on Seller's material return authorization form. **PRODUCTS OR PARTS RETURNED WITHOUT PRIOR WRITTEN PERMISSION OF SELLER WILL NOT BE ACCEPTED FOR CREDIT.** Expenses incurred by Customer in returning, replacing or removing the Products will not be reimbursed by Seller. If the defect comes under the terms of the limited warranty, the Products will be repaired or replaced and returned to the Customer and the cost of return freight will be paid by Seller. The remedy of repair or replacement provided for herein is Customer's exclusive remedy. Any improper use, alteration, repairs, tampering, misapplication, improper installation, application of improper voltage or any other action or inaction by Customer or others (including the use of any unauthorized service agency) that in Seller's sole judgment adversely affects the Product shall void this warranty. The warranty expressly provided herein may only be asserted by Customer and may not be asserted by Customer's customers or other users of the Products; provided, however, that if Customer is an authorized equipment dealer of Seller, Customer may assign the warranty herein to Customer's customers, subject to all of the limitations of these Terms, and in such case, the warranty shall be exclusively controlled by Seller in accordance with these Terms. **THIS LIMITED WARRANTY IS EXCLUSIVE AND IS IN LIEU OF ANY OTHER WARRANTY, EXPRESSED OR IMPLIED, INCLUDING BUT NOT LIMITED TO ANY IMPLIED WARRANTY OF NONINFRINGEMENT, MERCHANTABILITY OR FITNESS FOR A PARTICULAR PURPOSE, WHICH ARE EXPRESSLY DISCLAIMED.**

Ninety (90) Day Parts-Only Warranty:

Replacement Parts

Notwithstanding anything herein to the contrary, the limited warranty herein will not cover components in Seller's sole discretion such as, but not limited to, the following: damage to touchscreens and conveyor belts from abuse or impact; wear items such as air filters; damage to catalyst from use of non-approved cleaning products; product misuse, tampering, or misapplication; improper installation; lack of or improper cleaning; or application of improper voltage.

LIMITATION OF LIABILITY:

SELLER WILL NOT BE LIABLE FOR ANY INDIRECT, INCIDENTAL, CONSEQUENTIAL, PUNITIVE, EXEMPLARY, OR SPECIAL DAMAGES, INCLUDING WITHOUT LIMITATION ANY LOST PROFITS, COSTS OF SUBSTITUTE PRODUCTS, OR LABOR COSTS, ARISING FROM THE SALE, USE, OR INSTALLATION OF THE PRODUCTS, FROM THE PRODUCTS BEING INCORPORATED INTO OR BECOMING A COMPONENT OF ANOTHER PRODUCT, OR FROM ANY OTHER CAUSE WHATSOEVER, WHETHER BASED ON WARRANTY (EXPRESSED OR IMPLIED) OR OTHERWISE BASED ON CONTRACT, TORT, OR ANY OTHER THEORY OF LIABILITY, AND REGARDLESS OF ANY ADVICE OR REPRESENTATIONS THAT MAY HAVE BEEN RENDERED BY SELLER CONCERNING THE SALE, USE, OR INSTALLATION OF THE PRODUCTS, EVEN IF SELLER IS AWARE OF THE POSSIBILITY OF SUCH DAMAGES. IN NO EVENT WILL SELLER'S AGGREGATE LIABILITY ARISING OUT OF OR RELATED TO THIS AGREEMENT EXCEED THE TOTAL AMOUNTS PAID TO SELLER BY CUSTOMER FOR THE PRODUCTS WITHIN THE THREE (3) MONTH PERIOD IMMEDIATELY PRECEDING THE EVENT GIVING RISE TO CUSTOMER'S CLAIM. THE LIMITATIONS SET FORTH HEREIN REGARDING SELLER'S LIABILITY SHALL BE VALID AND ENFORCEABLE NOTWITHSTANDING A FAILURE OF ESSENTIAL PURPOSE OF THE LIMITED REMEDY SPECIFIED IN THESE TERMS.

Ovention, Inc.
P.O. Box 340500
Milwaukee, WI 53234-0500 U.S.A.
855-298-OVEN(6836)
connect@oventionovens.com
partsandservice@oventionovens.com
www.oventionovens.com



Need help?
Call our toll-free
Ovention Hotline
855-298-OVEN(6836)