

OVENTION®



Ovention Plant
STURGEON BAY, WI

Ovention Customer Service
MILWAUKEE, WI

Employee owned

Ovention ovens are designed and manufactured in the heartland of the USA. Between our manufacturing facility in Sturgeon Bay, WI and our first-class customer service based in Milwaukee, WI, Ovention is committed to serving you and making ourselves accessible to you.

We take pride in providing you with a premium-quality design worthy of your business.

The Ovention® advantage

LABOR SAVINGS

Proprietary technologies like auto loading and unloading saves valuable time.

ENERGY EFFICIENCY*

Energy savings and ease of use help you serve food faster and easier with a reduced carbon footprint.

VENTLESS TECHNOLOGY

UL®-KNLZ certified ventless ovens give you more installation flexibility which saves you money.

FAST DELIVERY

With one of the industry's shortest lead times, we ensure you get what you ordered, when you need it.

CULINARY SUPPORT

Our culinary team, convenient Menu Builder, and other online tools support you and your menu creation.

SOUS VIDE ADVANTAGE

All Ovention ovens can do finishing and retherming sous vide cooked food perfectly!

*See energy efficiency section in foldout for more details.

UL® is a trademark of Underwriters Laboratories, Inc.



Cook with complete versatility

At Ovention, we think ovens should be smart enough to cook your entire menu perfectly, every time.





Precision Impingement® Technology

Precision Impingement technology utilizes hot air for a fast, high-quality cook without microwaves. With three times the airflow velocity, speed and quality increases – giving you delicious food every time.

Matchbox® M360, Matchbox® M1817/1313, Shuttle® S1200/1600/2000/2600, Conveyor C1400/2000/2600

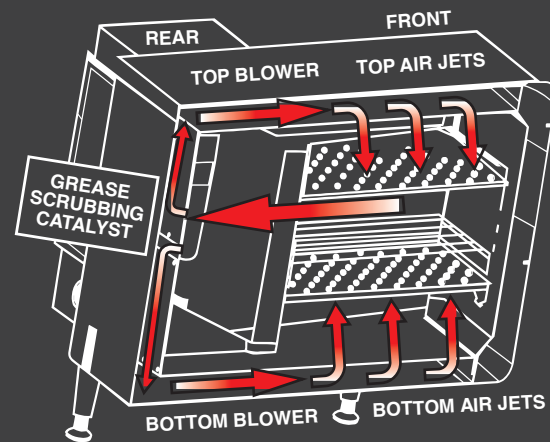

Microwave Speed Assist

MiSA® brings microwave technology to the Ovention® line. That's right- microwave. MiSA brings efficiency, performance, and quality to rapid cooking. Consistent browning with our patent-pending artisanal plate, low energy consumption, and easy cleanup are just a few of the reasons you will be glad to have MiSA at your disposal for all of your rapid cooking needs.

Microwave Speed Assist: MiSA®-a12, MiSA®-a16*
Coming Soon!

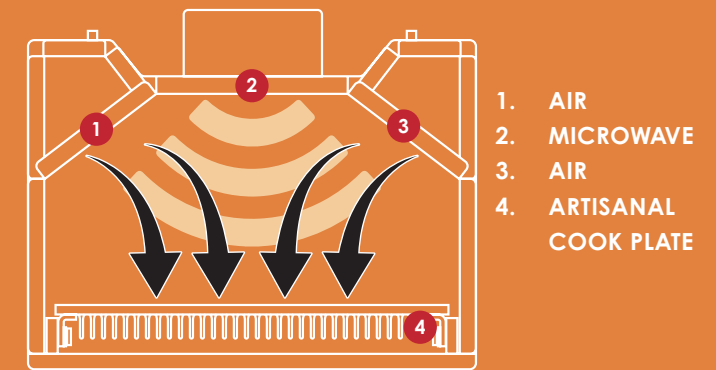

Linear Impingement and Infrared

MiLO® uses a first-of-its-kind, patented technology called Linear Impingement and Infrared (IR), the first successful integration of hot air and IR in an oven that applies the strength of each technology. The hot air in the enclosed cavity allows for even, consistent cooking and a higher yield. The IR elements on both top and bottom of each cavity provide more efficient caramelization without over-drying.

Linear Impingement and Infrared: Single MiLO® 14, Single MiLO® 16, Double MiLO2® 16

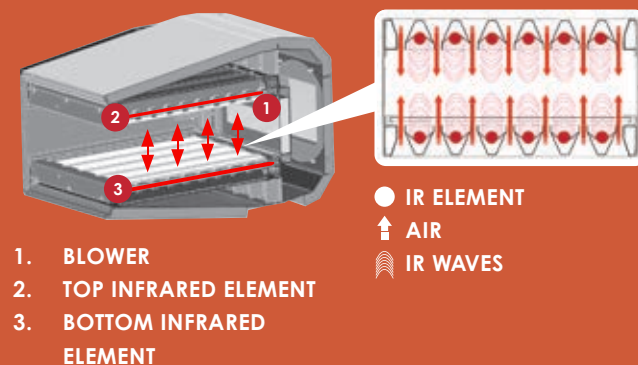

Infrared Only Finishing

The F1400 is a robust infrared (IR) conveyor oven. This operator-friendly conveyor will sear, melt, toast, and finish your food products to perfection.

Infrared Only Finishing: F1400

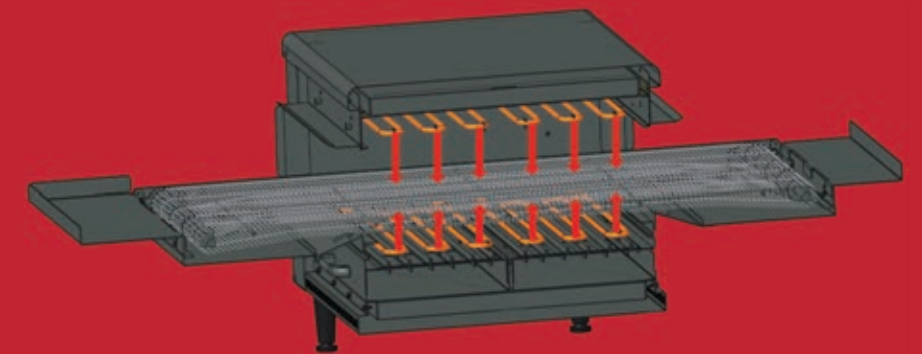



Ventless certified

- UL®-KNLZ certified for operation *without* a Type 1 hood in accordance with EPA 202 test.
- UL listed for multiple stacking configurations.
- Performs up to 10x better than the required UL grease emissions standard.



Ovention® emissions test results

Limit = 5.0mg/m³

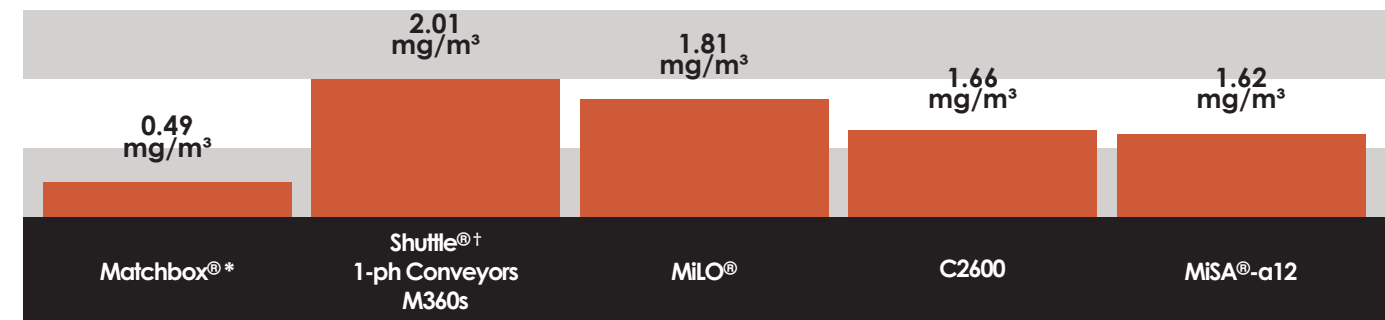













* The value shown reflects the largest unit tested for this model. The smaller units did not require EPA 202 testing by UL since the larger units were all below the 5.0 mg/m³ limit.

† The S2000 Shuttle® was tested in conveyor mode because it was determined to be the most demanding condition.

‡ The F1400 is UL®-KNLZ listed with ventless operation for re-thermalization of pre-cooked product

UL® is a registered trademark of Underwriters Laboratories, Inc.

How quiet is an Ovention® oven?

OVEN	dB
 Finishing Oven F1400	54
 MiLO® 2-16	68
 Matchbox® 1718	66
 Conveyor 2000	66
 MiSA® -a12	64
 Shuttle® 2000	62
 TurboChef® 2020	79
 TurboChef® Double Batch	81
 TurboChef® Bullet	76
 Ambient	44
 Normal Conversation	60
 Lawn Mower	85

Measurement was taken 2 feet in front of the oven.
 Ambient was measured before each oven.
A 10 dB increase is equal to a doubling in volume.

TurboChef® is a trademark of TurboChef Technologies, Inc.



There's an
Ovention® oven
right for you!



Matchbox® 1313/1718



Matchbox® M360-14



Shuttle® 1200/1600/2000/2600



Conveyor 1400/1600HD/2000/2600



MiLO® Single 14/Single 16/Double 16



Finishing Oven F1 400



MiSA®-a12/a16

Matchbox® | Sizes 1313/1718



Matchbox utilizes our patented Precision Impingement® and labor-saving dual auto loading and unloading technologies. Customize cook time, independent blower speeds and temperature for each item, so you get maximum cooking control and incredible quality.

Ovention is constantly improving and expanding our portfolio of cooking solutions. Visit [oventionovens.com](https://www.oventionovens.com) for more details. This product is covered by patents in the US and other countries. UL® is a trademark of Underwriters Laboratories, Inc.

STANDARD FEATURES

- Patented sealed cooking chamber with 2 to 8 times the airflow rate reduces cook times and lower energy consumption lessening operating costs by 40-50%, compared to a traditional conveyor oven
- Independently controlled top and bottom Precision Impingement air with variable-speed
- It utilizes our labor-saving dual auto load and unload technology
- FlexTemp™ dynamic temperature management allows $\pm 50^{\circ}$ F between cook cycles
- Quiet; maximum decibel (dB) level of 67
- Certified UL®-KNLZ ventless; stackable
- 1 year parts and labor warranty

OPERATION & PERFORMANCE

- Intuitive full-color, front-facing touchscreen controls can store 1000+ multistage recipes
- Industry leading online menu & recipe software allows for easy menu creation and management via USB drive
- Self-diagnostics for monitoring oven components and performance
- High visibility countdown timers
- Grill, roast, bake, steam, broil, and air fry
- Easy-to-clean design
- Use any oven safe pans; specialty pans and accessories are available through your local dealer or at [oventionovens.com](https://www.oventionovens.com)



12" Thin Crust Pizza
2:00



SCAN HERE TO
VIEW SPEC SHEET



OVENTION

Matchbox® M360 | Size 14



Matchbox M360 has all of the benefits of the Matchbox in a smaller footprint with a unique carousel loading platform. It utilizes our labor-saving dual auto load and unload technology. Customize cook time, independent blower speeds and temperature for each item, so you get maximum cooking control and incredible quality.

Ovention is constantly improving and expanding our portfolio of cooking solutions. Visit [ventionovens.com](https://www.ventionovens.com) for more details. This product is covered by patents in the US and other countries. UL® is a trademark of Underwriters Laboratories, Inc.

*M360 Coming in 2023

STANDARD FEATURES

- Patented sealed cooking chamber with 2 to 8 times the airflow rate reduces cook times and lowers energy consumption lessening operating costs by 40-50%, compared to a traditional conveyor oven
- Independently controlled top and bottom Precision Impingement air with variable-speed
- Patented auto loading & unloading capability with 360° rotating deck
- FlexTemp dynamic temperature management allows $\pm 25^\circ$ F between cook cycles
- Quiet; maximum decibel (dB) level of 79
- Certified UL®-KNLZ ventless; stackable
- 1 year parts and labor warranty

OPERATION & PERFORMANCE

- Intuitive full-color, front-facing touchscreen controls can store 1000+ multistage recipes
- Industry leading online menu & recipe software allows for easy menu creation and management via USB drive
- Self-diagnostics for monitoring oven components and performance
- High visibility countdown timers
- Grill, roast, bake, steam, broil, and air fry
- Easy-to-clean design
- Use any oven safe pans; specialty pans and accessories are available through your local dealer or at [ventionovens.com](https://www.ventionovens.com)



Chocolate Chip Cookies
8:00



SCAN HERE TO
VIEW SPEC SHEET



OVENTION

Shuttle® | Sizes 1200/1600/2000/2600



The Shuttle sets the new standard for conveyor ovens everywhere. It combines the throughput benefits of an impingement conveyor as well as a closed cavity oven, all using our advanced Precision Impingement® technology. No other oven can operate as both a conveyor and a closed-cavity oven.

Oventron is constantly improving and expanding our portfolio of cooking solutions. Visit [ovationovens.com](https://www.ovationovens.com) for more details. This product is covered by patents in the US and other countries. UL® is a trademark of Underwriters Laboratories, Inc.

*S2600 Coming in 2023

STANDARD FEATURES

- Operate in either high-performance Conveyor or patented Shuttle mode with sealed baking chamber for menu flexibility and energy efficiency
- Independently controlled top and bottom Precision Impingement air
- Left or right feed conveyor belt direction changeable with control settings for linear flow
- Patented dual auto-load & unload capability
- FlexTemp dynamic temperature management allows $\pm 25^{\circ}$ F between cook cycles
- Automatic Power Save mode
- Quiet; maximum decibel (dB) level of 69
- Certified UL®-KNLZ ventless; stackable
- 1 year parts and labor warranty

OPERATION & PERFORMANCE

- Store 1000+ multistage recipes
- Industry leading online menu & recipe software allows for easy menu creation and management via USB drive
- Self-diagnostics for monitoring oven components and performance
- High visibility countdown timers
- Grill, roast, bake, steam, broil, and air fry
- Easy-to-clean design
- Use any oven safe pans; specialty pans and accessories are available through your local dealer or at [ovationovens.com](https://www.ovationovens.com)



Toasted Ham & Cheese Sandwich
1:15



SCAN HERE TO
VIEW SPEC SHEET



OVENTRON

Conveyor | Sizes 1400/2000/2600



Simple, smart and the right fit for operators seeking a high-throughput conveyor oven. The most technologically elegant and operator-friendly conveyor on the market today.

Ovention is constantly improving and expanding our portfolio of cooking solutions. Visit [ovationovens.com](https://www.ovationovens.com) for more details. This product is covered by patents in the US and other countries. UL® is a trademark of Underwriters Laboratories, Inc.

STANDARD FEATURES

- Independently controlled top and bottom Precision Impingement® air with variable-speed recirculation
- Left or right feed conveyor belt direction changeable with control settings
- Factory-installed Power Save setting available for maximum energy conservation
- Quiet; maximum decibel (dB) level of 72
- Certified UL®-KNLZ ventless; stackable
- 1 year parts and labor warranty

OPERATION & PERFORMANCE

- Intuitive front-facing touchscreen controls can store 36+ recipes
- Industry leading online menu & recipe software allows for easy menu creation and management via USB drive
- Self-diagnostics for monitoring oven components and performance
- High visibility countdown timers
- Grill, roast, bake, steam, broil, and air fry
- Easy-to-clean design
- Use any oven safe pans; specialty pans and accessories are available through your local dealer or at [ovationovens.com](https://www.ovationovens.com)



Precooked Chicken Wings
23 lbs/hour



SCAN HERE TO
VIEW SPEC SHEET



OVENTION

Heavy Duty Conveyor | 1600HD



Simple, fortified version of our conveyor line for reliable operation.

Ovention is constantly improving and expanding our portfolio of cooking solutions. Visit [ventionovens.com](https://www.ventionovens.com) for more details.
This product is covered by patents in the US and other countries.
UL® is a trademark of Underwriters Laboratories, Inc.

*C1600HD Coming in 2023

STANDARD FEATURES

- Independently controlled top and bottom impingement air with 3 speed options (high, medium, low) recirculation
- Pending UL®-KNLZ certification for ventless operation
- New control panel: proven design, simple, intuitive functionality to draw cooler, cleaner air
- 3-speed blower design
- Additional internal airflow to keep oven cool
- Dishwasher safe jet plates
- Fortified construction for heavy use
- 1 year parts and labor warranty

OPERATION & PERFORMANCE

- Intuitive front-facing color controls can store 12+ recipes
- Recipe management and diagnostics via USB drive
- Grill, roast, bake, steam, broil, and air fry
- Use any oven safe pans; specialty pans and accessories are available through your local dealer or at [ventionovens.com](https://www.ventionovens.com)



Pizza
2:45

SCAN HERE TO
VIEW SPEC SHEET



OVENTION

MiLO® | Single 14/Single 16/Double 16



NEW: MiLO® Single 16
Can be stacked or free standing



Choose from a variety of anti-microbial powdercoat options!



MiLO utilizes a revolutionary infusion of linear impingement and infrared (IR) technologies. Independent top and bottom cavities, each with its own glass door, interior light and intuitive full-color touchscreen in a small footprint.

Ovention is constantly improving and expanding our portfolio of cooking solutions. Visit [oventionovens.com](https://www.oventionovens.com) for more details. This product is covered by patents in the US and other countries. UL® is a trademark of Underwriters Laboratories, Inc.

STANDARD FEATURES

- Patented Linear Impingement heating technology uses hot air in cavity for an even, consistent cook with higher yield
- independently controllable top and bottom IR elements provide caramelization without overdrying
- Full-color touchscreens for each cavity, allowing for each cavity to operate independently
- Glass door with illuminated interior
- Automatic Power Save mode when not cooking for maximum energy conservation
- Quiet; maximum decibel (dB) level of 67
- UL®-KNLZ certified for ventless operation
- Use MiLO-16 as a compact standalone unit or stack on a MiLO 2-16 for a ventless three-cavity configuration
- 1 year parts and labor warranty

OPERATION & PERFORMANCE

- Store 1000+ multistage recipes
- Industry leading online menu & recipe software allows for easy menu creation and management via USB drive
- Programmable cavity venting for humidity management
- Self-diagnostics for monitoring oven components and performance
- High visibility countdown timers
- Grill, roast, bake, steam, broil, and air fry
- Easy-to-clean design
- Use any oven safe pans; specialty pans and accessories are available through your local dealer or at [oventionovens.com](https://www.oventionovens.com)



Grilled Veggies
2:00

SCAN HERE TO
VIEW SPEC SHEET



OVENTION®

Finishing Oven | F1400



Choose from a variety of anti-microbial powdercoat options!



Finish your plates with ease and precision with this robust IR finishing oven. Melt, sear, toast and finish to perfection with this operator-friendly, quiet conveyor.

Ovention is constantly improving and expanding our portfolio of cooking solutions. Visit oventionovens.com for more details. This product is covered by patents in the US and other countries. UL® is a trademark of Underwriters Laboratories, Inc.

STANDARD FEATURES

- Quick-heating infrared elements and microprocessor to control temperature and cook time
- Full-color touchscreen display with security passcode and color controls
- Belt direction changeable by controls
- Independently control belt speed and heat on top and bottom from 0%-100%
- Belt direction and speed control 10-180s
- Patented Hatco® ColorGuard sensing system monitors and adjusts conveyor speed and temperature during high usage periods to ensure product color uniformity
- Built-in power save mode
- Small footprint gives high return per square foot of counter space
- Ultra quiet operation with a maximum decibel (dB) of 50
- Maximum internal temp of 825° F
- UL®-KNLZ listed ventless operation for re-thermalization of pre-cooked product
- 1 year parts and labor warranty

OPERATION & PERFORMANCE

- Holds 4 recipe settings
- Melts cheese in as little as 20 seconds
- Fits up to 14" pizza, half size sheet
- Perfect for melting toppings, finishing foods like potato skins, soup, nachos, as well as toasting buns and bread
- Great for thermalizing frozen or fresh foods like appetizers, French fries, and pizza
- Use any oven safe pans; specialty pans and accessories are available through your local dealer or at oventionovens.com



Nachos
0:30



SCAN HERE TO
VIEW SPEC SHEET



OVENTION

MISA® | Sizes a12/a16



Choose from a variety of anti-microbial powdercoat options!



MISA stands for **M**icrowave **S**peed **A**ssist. Cook up to 10x faster than conventional ovens without sacrificing quality. Our patent-pending cook plate technology gives you superior browning in less time. Higher quality, higher speed, smaller footprint.

Ovention is constantly improving and expanding our portfolio of cooking solutions. Visit [oventionovens.com](https://www.oventionovens.com) for more details. This product is covered by patents in the US and other countries. UL® is a trademark of Underwriters Laboratories, Inc.

*MiSA-a16 Coming In 2023

STANDARD FEATURES

- Highest convection heat, largest cavity volume, and quietest work environment in its size category (68 dB)
- Easy-to-clean non-stick (PTFE) liner on most interior surfaces
- Patent-pending artisanal cook plate for superior browning
- Industry leading online menu & recipe software allows for easy menu creation and management via USB
- Self-diagnostics for monitoring oven components and performance
- High visibility countdown timer
- Top launched microwave system with dual magnetrons and stirrers to ensure even distribution
- Certified UL®-KNLZ ventless individually and with two units on stacking cart
- 1 year parts and labor warranty

OPERATION & PERFORMANCE

- Simple, intuitive touchscreen can store 1000+ recipes with dozens of standard icons and full color product images
- Cooks up to 10 times faster than conventional ovens
- Use any oven-safe pans; pans for scoring or cooking specialty menu items are available through your local dealer or at [oventionovens.com](https://www.oventionovens.com)
- Fits 12" pizza, quarter size sheet pan
- Perfect for certain food products like breakfast sandwiches, taquitos, corn dogs, egg rolls and more
- Industry-leading online menu & recipe software allows for easy menu creation and management via USB drive
- Self-diagnostics for monitoring oven components and performance
- Grill, roast, bake, steam, broil, and air fry
- Easy-to-clean design



Breakfast Sandwich
0:45



SCAN HERE TO
VIEW SPEC SHEET



OVENTION



Matchbox® 1313



Matchbox® 1718



Shuttle® 1200



Shuttle® 1600



Shuttle® 2000



Shuttle® 2600



Finishing Oven F1400



Conveyor 1400



Conveyor 1600HD



Conveyor 2000



Conveyor 2600

	Matchbox® 1313	Matchbox® 1718	Shuttle® 1200	Shuttle® 1600	Shuttle® 2000	Shuttle® 2600	Finishing Oven F1400	Conveyor 1400	Conveyor 1600HD	Conveyor 2000	Conveyor 2600
Heating Technology	Precision Impingement®	Precision Impingement®	Precision Impingement®	Precision Impingement®			Infrared Finishing	Precision Impingement®		Precision Impingement®	Precision Impingement®
Capacity	Precision Impingement®			Precision Impingement®			Precision Impingement®		Precision Impingement®		
Maximum Pan Size	Quarter Sheet Pan	Half Sheet Pan	Half Sheet Pan (horizontally)	Half Sheet Pan	Full Sheet Pan or Full Hotel Pan	Full Sheet Pan or Full Hotel Pan	Half Sheet Pan	Half Sheet Pan	Half Sheet Pan	Full Hotel Pan	Full Sheet Pan or Full Hotel Pan
Maximum Pie Size	12"	16"	14" (Conveyor mode) 12" (Shuttle mode)	16"	18" (Conveyor mode) 16" (Shuttle mode)	18" (Conveyor mode) 16" (Shuttle mode)	14"	14"	16"	18"	24"
Exterior Dimensions*	Precision Impingement®			Precision Impingement®			Precision Impingement®		Precision Impingement®		
Height without Legs (legs approx. 4")	16.24" (413mm)	16.24" (413mm)	16.24" (413mm)	16.62" (422mm)	16.24" (413mm)	16.24" (413mm)	18.5" (368 mm)	16.24" (413mm)	16.66" (423 mm)	16.24" (413mm)	16.24" (413mm)
Width	49.85" (1267mm)	61.69" (1567mm)	44.22 (1123mm)	56.84" (1494mm)	48.25" (1225mm)	63.35" (1610mm)	39.6" (1006 mm)	38.50 (978mm)	38.78" (985 mm)	48.26" (1226mm)	48.13" (1223mm)
Depth	28.73" (730mm)	34.47" (876mm)	31.05 (789mm)	32.91" (836mm)	37.01" (940mm)	43.01" (1092mm)	23.8" (605 mm)	31.05" (789mm)	35.11" (892 mm)	37.01" (940mm)	43.01" (1092mm)
Cook Cavity	Precision Impingement®			Precision Impingement®			Precision Impingement®		Precision Impingement®		
Height x Width x Depth	3.5"x13"x13" (89x330x330mm)	3.5"x17"x18" (89x432x458mm)	3.5"x17"x14.6" (89x434x371mm)	3.5"x20"x16.54" (89x508x420mm)	3.5"x20"x20.54" (89x508x522mm)	3.5"x20"x26.54" (89x508x674mm)	4.0"x17"x14.59" (102x432x371mm)	3.5"x17"x14.6" (89x432x371mm)	3.3"x21.97"x16.92" (84x558x430mm)	3.5"x20"x20.54" (89mmx508x522mm)	3.5"x48"x26.54" (88.9x1219x674mm)
Cook Surface/Belt Width x Depth	N/A	N/A	14.8"x14" (376x356mm)	56.54"x16" (1436x660mm)	56.54"x20" (1436x508mm)	56.54"x26" (1436x660mm)	38.5"x14" (978x356mm)	38.5"x14" (978x356mm)	16.0"x38.78" (406x985 mm)	20"x48" (508x1219mm)	48"x26" (1219x660mm)
Belt Options	N/A	N/A	N/A	N/A	N/A	N/A	Single Belt	Single Belt	Single Belt	Single Belt: 20" (508mm)	Single Belt: 26" (660mm)
Features	Precision Impingement®			Precision Impingement®			Precision Impingement®		Precision Impingement®		
Stackable	Stackable	Stackable	Stackable	Stackable	Stackable	Stackable	Stackable	Stackable	Stackable (TBD)	Stackable	Stackable
Recipe Stages	Multi-stage Recipe	Multi-stage Recipe	Multi-stage Recipe (Shuttle mode only)	Multi-stage Recipe (Shuttle mode only)	Multi-stage Recipe (Shuttle mode only)	Multi-stage Recipe (Shuttle mode only)	Single Stage Recipe	Single Stage Recipe	Single Stage Recipe	Single Stage Recipe	Single Stage Recipe
USB Compatible	USB Compatible	USB Compatible	USB Compatible	USB Compatible	USB Compatible	USB Compatible	USB compatible	USB Compatible	USB Compatible	USB Compatible	USB Compatible
UL® Ventless	Ventless	Ventless	Ventless	Ventless	Ventless	Ventless	Ventless	Ventless	Ventless (TBD)	Ventless	Ventless
Power	Precision Impingement®			Precision Impingement®			Precision Impingement®		Precision Impingement®		
Plug	NEMA 6-30	NEMA 6-50	NEMA 6-30 NEMA 6-50	NEMA L15-30	NEMA 6-50 NEMA 15-50	NEMA 6-50 NEMA 15-50	NEMA 6-50 NEMA 6-30	NEMA 6-50 NEMA L15-30 NEMA 15-50	NEMA 6-50	NEMA 15-50 NEMA 6-50	NEMA 15-50
Energy Efficiency**	Precision Impingement®			Precision Impingement®			Precision Impingement®		Precision Impingement®		
Total Energy Cost/Day	\$2.81	\$4.52	\$2.97	\$3.71	\$3.99	\$4.19	\$7.62	\$5.60	\$168.00	\$6.77	\$8.69
Total Energy Cost/Month	\$84.00	\$136.00	\$89.03	\$111.00	\$120.00	\$125.67	\$229.00	\$2016.00	\$2,016.00	\$203.00	\$260.79
Total Energy Cost/Year	\$1,010.00	\$1,627.00	\$1,068.37	\$1,335.00	\$1,436.00	\$1,508.07	2,748.00	\$2,016.00	\$2,016.00	\$2,439.00	\$3,129.45
Average Load***	Precision Impingement®			Precision Impingement®			Precision Impingement®		Precision Impingement®		
Watts	2,814 W	3,425 W	2,248 W	2,810 W	3,022 W	3,174 W	5,871 W	4,370 W	TBD	5,132 W	6,586 W
kBTU/hour	7.3 kBTU/hour	11.7 kBTU/hour	7.7 kBTU/hour	9.6 kBTU/hour	10.3 kBTU/hour	10.84 kBTU/hour	20.1 kBTU/hour	14.9 kBTU/hour	TBD	17.5 kBTU/hour	22.5 kBTU/hour
Ton of AC	0.61 Tons of AC	0.97 Tons of AC	0.64 Tons of AC	0.80 Tons of AC	0.86 Tons of AC	0.9 Tons of AC	1.67 Tons of AC	1.24 Tons of AC	TBD	1.46 Tons of AC	1.87 Tons of AC
Operating Assumption	Precision Impingement®			Precision Impingement®			Precision Impingement®		Precision Impingement®		
Cooking Mode	25% of day 3 hrs/day	25% of day 3 hrs/day	N/A	N/A	N/A	N/A	N/A	N/A	TBD	N/A	N/A
Idle Mode	75% of day 9 hrs/day	75% of day 9 hrs/day	N/A	N/A	N/A	N/A	N/A	N/A	TBD	N/A	N/A
Energy Save Mode	N/A	N/A	75% of day 9 hrs/day	75% of day 9 hrs/day	75% of day 9 hrs/day	75% of day 9 hrs/day	34% of day 4.08 hrs/day	34% of day 4.08 hrs/day	TBD	34% of day 4.08 hrs/day	34% of day 4.08 hrs/day
Idle-Open Oven	N/A	N/A	0% of day 0 hrs/day	0% of day 0 hrs/day	0% of day 0 hrs/day	0% of day 0 hrs/day	41% of day 4.92 hrs/day	41% of day 4.92 hrs/day	TBD	41% of day 4.92 hrs/day	41% of day 4.92 hrs/day
Cooking Shuttle	N/A	N/A	25% of day 3 hrs/day	25% of day 3 hrs/day	25% of day 3 hrs/day	25% of day 3 hrs/day	N/A	N/A	TBD	N/A	N/A
Cooking Conv.	N/A	N/A	0% of day 0 hrs/day	0% of day 0 hrs/day	0% of day 0 hrs/day	0% of day 0 hrs/day	25% of day 3 hrs/day	25% of day 3 hrs/day	TBD	25% of day 3 hrs/day	25% of day 3 hrs/day

* Different sized endstops available for Shuttles and Conveyors. Cook cavity dimensions are listed without endstops. ** Assuming \$0.11 energy cost and 12 hours of operation/day. *** Measurements shown with 1phase options. 3phase numbers available upon request. All specs subject to change based on final approvals. Additional and export plug configurations available upon request.



MiLO® Single 14



MiLO® Single 16/Double 16



MiSA® -a12



Matchbox® M360 14

Heating Technology

Linear Impingement and Infrared

Linear Impingement and Infrared

Microwave Speed Assist

Precision Impingement®

Capacity

Quarter Sheet Pan
14"

Half Sheet Pan
16"

Quarter Sheet Pan
12"

Customer Pan
20" or 18"

Exterior Dimensions*

21.7" (552mm)
23.4" (595mm)
32.2" (817mm)

16.5" (419mm) Single/30.9" (785mm) Double
28.9" (735mm)
32.6" (828mm)

22.26" (566mm)
16" (407mm)
29.15" (741mm)

17.28" (439mm)
41.11" (1044mm)
35.89" (911mm)

Cook Cavity

4"x15.5"x14.3" (102x394x363mm)
15.5"x14.3"(394x363mm)
N/A

4"x17.5"x18.3" (102x445x465mm)
17.5"x18.3" (445x465mm)
N/A

6.4"x12.9"x13.56" (163x328x345mm)
N/A

3.75"x28.25"x14.2" (96x718x 361mm)
N/A
N/A

Features

No
Multi-stage Recipe
USB Compatible
UL Ventless

Stackable
Multi-stage Recipe
USB Compatible
Ventless

Stackable
Multi-stage Recipe
USB Compatible
Ventless

No
Multi-stage Recipe
USB Compatible
Ventless

Power

NEMA 6-30
NEMA 15-50

NEMA 6-50 (MiLO 2-16 only)
NEMA 6-30 (MiLO-16 only)
NEMA 15-50

NEMA 6-30

NEMA 6-50

Energy Efficiency**

\$2.06
\$61.76
\$741.17

\$2.45 Sgle. / \$4.90 Dbl.
\$ 73.59 Sgle. / \$146.89 Dbl.
\$ 883.13 Sgle. / \$1,762.70 Dbl.

\$2.45
\$73.49
\$881.83

\$3.75
\$112.62
\$1351.43

1,586 W
5.4 kBTU/hour
0.45 Tons of AC

1,868 W Sgle. / 3,709 W Dbl.
6.35 kBTU/hr Sgle. / 12.67 kBTU/hr Dbl.
0.53 Tons of AC Sgle. /1.06 Tons of AC Dbl.

1,856 W
6.3 kBTU/hour
0.53 Tons of AC

2,844 W
9.71 kBTU/hour
0.81 Tons of AC

25% of day | 3 hrs/day
75% of day | 9 hrs/day

25% of day | 3 hrs/day
75% of day | 9 hrs/day

25% of day | 3 hrs/day
75% of day | 9 hrs/day

25% of day | 3 hrs/day
75% of day | 9 hrs/day

N/A
N/A
N/A
N/A

N/A
N/A
N/A
N/A

N/A
N/A
N/A
N/A

N/A
N/A
N/A
N/A

Ovention® offers
a wide range
of accessories...



Egg Pan
(OV-EGGRND-1/2) (OV-EGGRND-1/4)

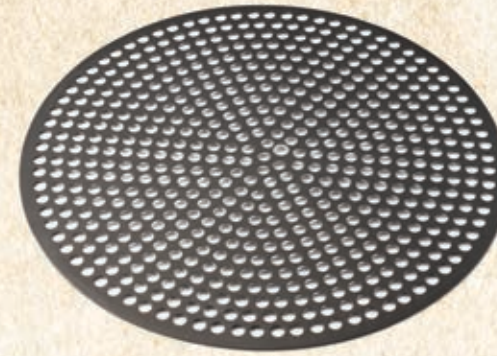

Heavy Duty Pizza Screen
(OV-HDSCREEN-16)



Warming Tray
(OV-WRM-MISA1)

Grill Plate
(OV-GRLPLT-12x12)

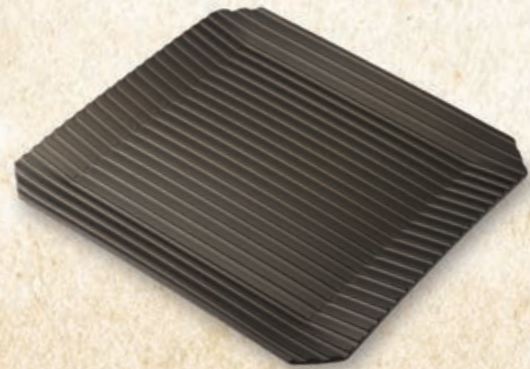

Perforated Pan
(OV-1/2PAN-PERF)



...to cook, finish,
and serve your
product the way
YOU want!

Pizza Rocker
(OV-ROCKER)



OVENTION®

Anti-microbial powder coat

All powder coat options now come standard with an anti-microbial additive.

Anti-microbial coatings use naturally-occurring, environmentally sustainable silver ions to help inhibit the growth of microbes on the powder coated surfaces of the oven.

How do the coatings work? When moisture is present, the anti-microbial coatings release silver ions, which attach to a microbe's cellular structure to inhibit its growth. The coatings also retain their anti-microbial protection over time.

The silver ions offer protection against microbes that cause odor, mildew and spoilage without high toxicity to humans and animals.



Choose from a variety of anti-microbial powdercoat options!



CANDY APPLE



BURNT ORANGE



SWEET POTATO



MAC & CHEESE



LEMON



LIME



BLUE CURAÇAO



BLUEBERRY



SEAWEED



GRAPHITE



BLACK

What can I cook?

At Ovention®, we think ovens should be smart enough to cook your entire menu perfectly, every time.



GRILL

Paninis | Precooked Bratwurst
Shrimp | Pineapple
Vegetables



BROIL

Lobster Tails | Zucchini
Shrimp | Fish
Stuffed Mushrooms



AIR FRY

Precooked Chicken Wings
Onion Rings | Tater Tots
French Fries | Mozzarella Sticks



BAKE

Cookies | Pizza | Biscuits
Spinach & Artichoke Dips
Soufflé



STEAM

Vegetables | Rice
Pasta | Fish
Mussels



RAPID COOK

Taquitos | Corn Dogs
Precooked Meatballs
Breakfast Burritos | Egg Rolls

Cooking times

See how fast you can cook with an Ovention oven.



MATCHBOX®

Jumbo Pretzel | 0:40
Glazed Donut (Retherm) | 0:45
Potato Wedges | 3:30



SHUTTLE®

Quesadilla | 2:00
Flatbread | 1:45
Waffle Fries | 3:00



MISA®

Ham & Cheese Sandwich | 0:30
Egg Rolls (Frozen) | 2:30
Precooked Wings (Frozen) | 3:30



CONVEYOR

Par Baked Pizza | 2:30
Toasted Sub | 0:50
Asparagus | 2:00



MILO®

Cheesy Bread | 1:15
Bell Peppers | 2:15
Fresh Dough Pizza | 3:30



FINISHING OVEN

Nachos | 0:30
Baked Pasta | 2:00
Burrito | 0:30

Ovention has improved our overall quality of service and speed of production.

I would definitely recommend it.

– C2600 customer

If I want to customize, I can do that with the speed, time or heat...

It's a really, really good tool to have.

– MiLO® 14 customer

Ovention® has given us universal utility. It is the **heart** of our kitchen.

– S2000 customer

There's no guesswork....

It's been worth its weight in gold.

– M1718 customer

OVENTION®